



Walkie/Rider Motorized Hand Pallet Truck

B60Z^{AC} Series



The Safe Choice

PRODUCTIVITY:

The Hyster B60Z^{AC} is the simplest way to boost your productivity. It is easy to operate, has minimal service requirements and works smartly.

- Truck features a full six inches of lift height for easy maneuverability over uneven floor surfaces and across dock plates.
- The short head length and design of the control handle allows for the best turning radius and right angle stacking capabilities in its class.
- Pace setting travel speeds allow more loads to be moved per hour.
- A high performance hydraulic system, coupled with the advanced pallet entry/exit system, produces outstanding cycle times.
- Optional Coast Control with Side Glide feature enhances operator performance and productivity while increasing low level order picking efficiency.
 - Coast Control available with Advanced activation or Manual activation.
- Power Assist Steer option helps operators move heavy loads through tight turns and crowded loading areas with ease.
- Operator selectable, programmable performance modes enable the truck to be tailored to the application or operator skill level.
- AC traction controller provides improved torque, increased travel speeds and allows smoother acceleration and directional changes.
- Extended Shift Feature:
 - With Extended Shift “ON”, truck performance is tailored with “energy efficiency” in mind, allowing the truck to operate longer between battery charges.
 - With Extended Shift “OFF”, parameters are adjusted with high performance in mind, allowing quicker acceleration and directional changes, for faster cycle times resulting in increased throughput and productivity.

DEPENDABILITY:

The B60Z^{AC} sets the standard for long-lasting, worry free operation. Every detail is designed by Hyster engineers to make sure you can always deliver – and never get left holding the load.

- CANbus communication system significantly reduces the number of wires required in the electrical system, and links the control handle, display, controller and Power Assist Steer (option) together enhancing overall truck reliability.
- Steel reinforced control handle is durable, impact resistant and easy to service.
- Electro-mechanical brake has no linkage to adjust and maintain.
- Electronic horn provides high volume, consistent operation and long life.
- AC traction transistor controller eliminates motor brushes and directional contactors, creating a reliable product with minimal maintenance requirements.
- Integrated transistor pump control provides a “soft start” feature by eliminating the high in-rush current associated with contactors and, therefore, extends the service life of the pump motor.
- The AC system uses less energy than SEM systems, increasing overall truck performance while decreasing battery charge intervals.

ERGONOMICS:

The superior ergonomic design of the new B60Z^{AC} walkie/rider product means greater comfort for your operator. A comfortable operator is a more productive operator.

- Unique control handle design features left hand and right hand controls which allow finger tip control of lift/lower, travel and the horn functions with either hand.
- Coast Control with Side Glide feature eliminates climbing on/off during quick pick applications.
- Activation buttons for the optional Advanced Coast Control are conveniently positioned on each side of the steer handle for easy, effortless thumb operation from either side of the truck.
- 1-inch thick rubber floor mat absorbs shock from uneven floor surfaces or dock plates enhancing operator comfort when riding.
- Power Assist Steer option requires less effort from the operator, reducing fatigue and enhancing truck maneuverability.
- Padded and contoured steady rest provides a soft and comfortable grab point, increasing operator stability while riding.
- Low step height provides quick and easy on/off access for operator, reducing fatigue during the work shift.
- Large operator area provides comfortable and productive positioning.
- Ergonomically angled handgrips and contoured control handle provide a comfortable grip and enhance the maneuverability.



COST OF OPERATION:

One of the best ways to keep your profits up is to keep your equipment costs down. The Hyster B60Z^{AC} is designed to operate at the peak of efficiency so you can take your money straight to the bank.

- Three application/environmental packages are available to ensure you have the right truck for the job:
 - Standard Construction: +32° F to +120° F
 - Cooler/Freezer Package: 0° F to +120° F
 - **subZERO** Freezer Package: -40° F to +120° F
- Operator selectable, programmable performance modes that allow operators to tailor the truck to meet their preferred working style or to meet application requirements.
- CANbus communication system, coupled with easy motor and component access, simplifies the electrical system and increases diagnostic capabilities, which reduces down time.
- All wire harness connectors feature double sealed industrial type connections, which prevent moisture and other contaminants from entering the connector.
- The B60Z^{AC} is ETACC compatible and features on-board software interfacing, eliminating specialty tools and handsets.
- The electro-mechanical brake system has no linkage to maintain or adjust.
- Auto Deceleration System (ADS) utilizes regenerative braking, which significantly reduces brake wear, extending brake component life and reducing downtime.
- The design of the optional Advanced Coast Control saves valuable seconds each time the operator engages or disengages the system resulting in more pick time.

SERVICEABILITY:

The B60Z^{AC} features some of the latest technological advances of any Class III product in the market today. Because of these advances, service requirements are at a bare minimum, enhancing operation efficiency.

- Transistor Motor Control eliminates directional and lift pump contactors.
- AC traction motor has no brushes and commutator to maintain/replace.
- Backlit dash display allows easy reading in low/minimal light conditions.
- Electrical compartment cover is secured by spring clip retention, allowing removal of cover without tools.
- The electro-mechanical brake has no service requirements.
- Hall-effect throttle control is a non-contact device, eliminating wear components and requiring no mechanical adjustments.
- Lube fittings and serviceable bushings are used at all pivot points, reducing component wear and extending component life.
- Translucent hydraulic reservoir provides quick and easy fluid level check.
- Stationary traction motor design eliminates power cable flexing and potential for loose power wire connections.
- On-board diagnostic capability allows for quick troubleshooting, increasing truck uptime.
- CANbus communication system simplifies truck wiring and reduces the number of wires required.

THESE HYSTER® TRUCKS EXCEL IN EXTREME CONDITIONS

In cold room and freezer applications, your workers can keep warm by putting on a jacket or gloves. Your pallet trucks require a lot more protection. That's why the Hyster B60Z^{AC} series comes with two optional application/environmental packages for low-temperature applications.

The Cooler/Freezer Package is designed to operate in applications with temperature ranges from 0° F to +120° F.

The **subZERO** Freezer Package is designed to operate in applications with temperature ranges from -40° F to +120° F.



RAISING THE STANDARD FOR LIFT TRUCKS

Floor Mat: 1-inch thick rubber floor mat absorbs shock from uneven floor surfaces or dock plates enhancing operator comfort when riding.

Control Handle: The short head length and design of the control handle allows for the best turning radius and right angle stacking capabilities in its class.

Steady Rest: Padded and contoured to provide a soft and comfortable grab point, increasing operator stability while riding.

Load Backrest: Available in 48", 60", and 72" heights (bolt-on or pivoting).

Lift Height: Truck features a full six inches of lift height for easy maneuverability over uneven floor surfaces and across dock plates.

Brake: Electro-mechanical brake has no linkage to adjust and maintain.

Trucks shown with optional equipment.

STANDARD EQUIPMENT

- 48" Long Forks
- 27" Fork Spread
- Standard Construction Operating Temperatures: +32° F to +120° F
- Smooth Polyurethane Drive Tire – 90 Durometer – 10" x 5.0"
- Single Polyurethane Load Wheels – 3.25" x 6.5"
- Standard Duty Casters – Polyurethane Wheels
- Manual Steering
- Key Ignition Switch
- 24 Volt Transistor Control Electrical System
- AC Traction Motor (Brushless)
- Operator Selectable, Programmable Performance Modes
- Integrated "Soft Start" Transistor Lift Pump Control
- ADS (Auto Deceleration System) w/Regenerative Braking
- Extended Shift Feature
- 31.25" x 13.4" Open Battery Compartment
- Electro-Mechanical Park Brake
- UL Classification Type "E"
- Electronic Horn
- Impact Resistant, Steel Reinforced, Ergonomic Control Handle
- Pallet Exit Rollers/Entry Skids
- Knock-Out Load Wheel Axles
- 6" Lift Height
- Boxed Fork Construction with Reinforced Fork Tips
- Flush Pallet Stop
- Long Life Lift Linkage
- Multi-Function Display
 - Battery State of Charge
 - Hour Meter
 - Low Battery Lift Interrupt
 - Performance Mode Indicator
 - Fault Indicator
- On-Board Software
 - Test and Diagnose
 - No Handset Required
 - Password Protected

OPTIONAL EQUIPMENT

- Power Assist Steer
- Battery Rollers
- Convenience Tray (Load Backrest Mounted or Battery Mounted)
- RF Terminal Power Supply – 24 Volt
- Audible Alarm
- Visible Alarm – Pole Mounted Amber Strobe
- Advanced Coast Control with Side Glide
- Manual Coast Control with Side Glide
- Casters
 - Heavy Duty
 - Heavy Duty with SEALED Wheel and Swivel Bearings
- Fork Lengths
 - 36" Long Forks
 - 42" Long Forks
 - 60" Long Forks
- Drive Tire
 - Rubber – 65 Durometer
 - Siped Polyurethane – 90 Durometer
- Load Wheels
 - Single and Dual
 - 2 Bearing and 4 Bearing
 - Standard Bearing and SEALED Bearing
- Load Backrest
 - 48" High (Pivoting or Bolt-on)
 - 60" High (Pivoting or Bolt-on)
 - 72" High (Bolt-on)
- Application/Environmental Construction
 - Cooler/Freezer Package
 - Operating Temperatures: 0° F to +120° F
 - subZERO Freezer Package
 - Operating Temperatures: -40° F to +120° F

B60Z^{AC}

Bottom line? You need pallet trucks that can get the job done without a lot of fuss. The 6,000-lb. capacity B60Z^{AC} motorized hand pallet walkie/rider does just that. With its advanced productivity, exceptional durability and superior maneuverability, it's easy to see how the B60Z^{AC} can turn even your tough jobs into just another task.

DIMENSIONS

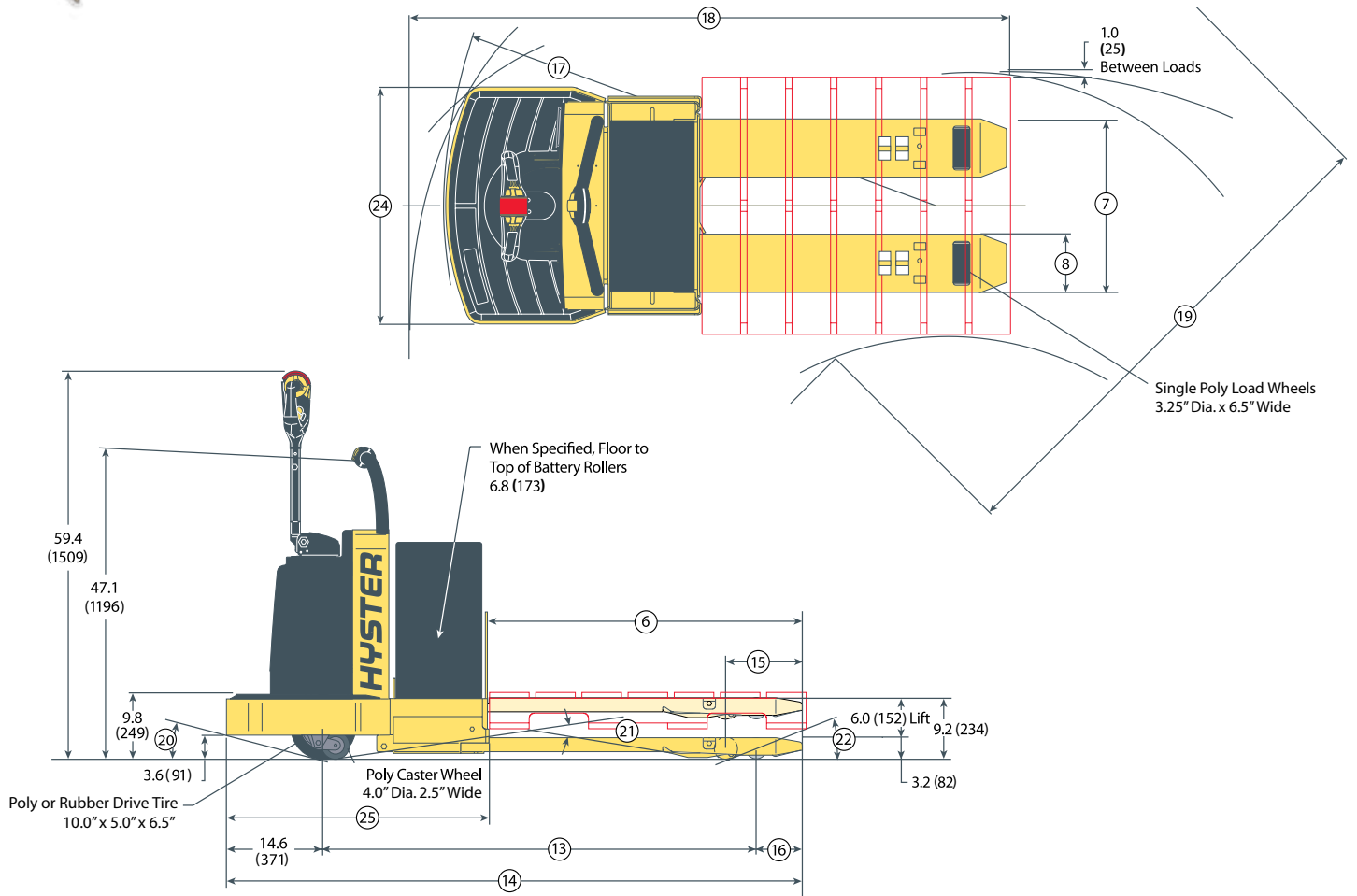

Circled dimensions correspond to the line numbers on the tabulated chart inside the Technical Guide. Dimensions are in inches (millimeters).

GMA Pallet - Standard Dimensions

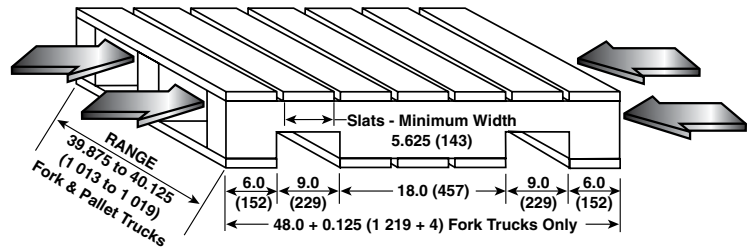

BATTERY SPECIFICATIONS								
Number of Cells	Cell Size	Plates per Cell	Capacity 6 Hr Rate	Battery Dimensions			Weight lb. (kg)	
				amp hr (kwh)	"X"	"Y"		"Z"
					in. (mm)	in. (mm)		in. (mm)
12	75	7	225 (5.2)	25.7 (652)	8.8 (224)	23.3 (592)	540 (245)	
12	85	7	255 (6.0)	25.7 (652)	8.8 (224)	23.3 (592)	570 (259)	
12	75	11	375 (8.7)	26.5 (673)	13.0 (330)	23.3 (592)	825 (374)	
12	85	11	425 (9.9)	26.5 (673)	13.0 (330)	23.3 (592)	865 (392)	
12	75	13	450 (10.5)	30.9 (785)	13.0 (330)	23.3 (592)	987 (448)	
12	85	13	510 (11.9)	30.9 (785)	13.0 (330)	23.3 (592)	1035 (469)	
12	100	13	600 (14.0)	30.9 (785)	13.0 (330)	26.2 (665)	1140 (517)	

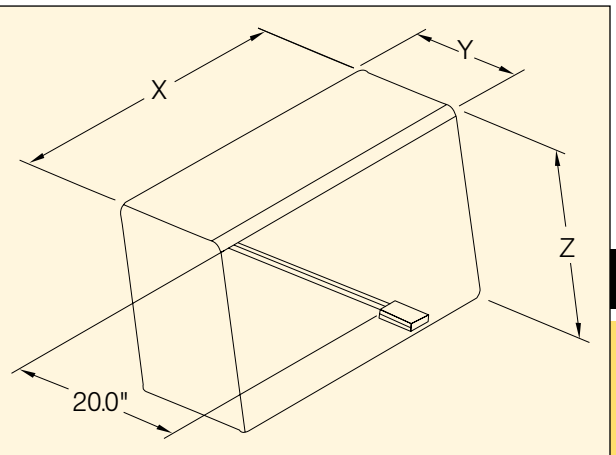

SPECIFICATIONS

7

GENERAL	1		HYSTER COMPANY					
	2		B60Z ^{AC}					
GENERAL	3		Battery - 24 Volt					
	4		Walk / Stand Ride					
GENERAL	5		6000 (2722)					
	6		Nominal	in (mm)	36 (914)	42 (1067)	48 (1219)	60 (1524)
GENERAL	6		Actual	in (mm)	35.75 (908)	41.75 (1060)	47.75 (1213)	59.75 (1518)
	7		in (mm)					
GENERAL	8		in (mm)					
	9		Lowered	in (mm)	28.75 (730)	34.75 (883)	40.75 (1035)	52.75 (1340)
WEIGHTS	10		No Load	lb (kg)	1237 (561)	1257 (570)	1272 (577)	1302 (591)
	11		Rated Load	lb (kg)	2268 (1029)	2566 (1164)	2807 (1273)	3212 (1457)
WEIGHTS	11		No Load	lb (kg)	1541 (699)	1601 (726)	1649 (748)	1760 (798)
	12		Rated Load	lb (kg)	6109 (2771)	5831 (2645)	5605 (2542)	5230 (2372)
WEIGHTS	12		No Load	lb (kg)	836 (379)	796 (361)	763 (346)	682 (309)
	13		Raised	in (mm)	49.2 (1250)	55.2 (1402)	61.2 (1554)	73.2 (1859)
DIMENSIONS	13		Lowered	in (mm)	53.8 (1367)	59.8 (1519)	65.8 (1671)	77.8 (1976)
	13		Raised	in (mm)	51.2 (1300)	57.2 (1453)	63.2 (1605)	75.2 (1910)
DIMENSIONS	13		Lowered	in (mm)	55.8 (1417)	61.8 (1570)	67.8 (1722)	79.8 (2027)
	14		in (mm)	75.3 (1913)	81.3 (2065)	87.3 (2217)	99.3 (2522)	
DIMENSIONS	14		in (mm)	77.3 (1963)	83.3 (2167)	89.3 (2268)	101.3 (2573)	
	15		Raised	in (mm)	11.7 (297)	11.7 (297)	11.7 (297)	11.7 (297)
DIMENSIONS	16		Lowered	in (mm)	7.0 (178)	7.0 (178)	7.0 (178)	7.0 (178)
	17		Raised	in (mm)	63.6 (1615)	69.6 (1768)	75.6 (1920)	87.6 (2225)
DIMENSIONS	17		Lowered	in (mm)	68.3 (1735)	74.3 (1887)	80.3 (2040)	92.3 (2344)
	17		Raised	in (mm)	65.6 (1666)	71.6 (1819)	77.6 (1971)	89.6 (2276)
DIMENSIONS	17		Lowered	in (mm)	70.3 (1786)	76.3 (1938)	82.3 (2090)	94.3 (2395)
	18		Raised	in (mm)	78.6 (1996)	83.7 (2126)	89.1 (2263)	100.0 (2540)
DIMENSIONS	18		Raised	in (mm)	80.4 (2042)	85.4 (2169)	90.9 (2309)	101.8 (2586)
	19		Raised	in (mm)	61.8 (1570)	64.9 (1648)	68.0 (1727)	74.3 (1887)
DIMENSIONS	19		Raised	in (mm)	63.3 (1608)	66.5 (1689)	69.6 (1768)	75.9 (1928)
	20		Chassis	%	26	26	26	26
DIMENSIONS	21		Ctr of Wheelbase	%	39	34	31	25
	22		Forks	%	39	39	39	39
DIMENSIONS	23		in (mm)	3.2 / 9.2 / 6.0 (81 / 234 / 152)				
	24		in (mm)	36.9 (937)				
DIMENSIONS	25		in (mm)	39.5 (1003)				
	26		in (mm)	31.25 x 13.4 x OPEN (793 X 340 X OPEN)				
PERF.	27		No Load/Rated Load	mph (kph)	9.0 / 6.7 (14.5 / 10.8)			
	27		No Load/Rated Load	mph (kph)	6.0 / 5.2 (9.7 / 8.4)			
PERF.	28		Type	AC				
	29		Type	Electro-Mechanical				
WHEELS	30		in	10.0 x 5.0 x 6.5 / Poly (1)				
	31		in	3.25 x 6.25 / Poly (2)				
	32		in	4.0 x 2.5 / Poly - Spring Loaded (2)				

Above specifications, unless otherwise listed, are for a standard truck without optional equipment.
 Right Angle Stack and Equal Intersecting Aisle are calculated using a 40" wide pallet.
 Grade Clearance measured to the bottom of the pallet with forks in a raised position.

CERTIFICATION: These Hyster® lift trucks meet design specifications of Part II ANSI B56.1-1969, as required by OSHA Section 1910.178(a)(2) and also comply with Part III ANSI B56.1-revision in effect at time of manufacture. Certification of compliance with the applicable ANSI standards appears on the lift truck.
NOTE: Performance specifications / ratings are for truck equipped as described under Standard Equipment in this Technical Guide. Performance specifications are affected by the condition of the vehicle and how it is equipped, as well as by the nature and condition of the operating area. Specifications are subject to change and the proposed application should be discussed with your authorized Hyster Dealer.

It's not just about the lift trucks.

Any company worth its weight knows success has just as much to do with the support before and after the sale as the sale itself. We pride ourselves on being more than just a lift truck manufacturer. Through our Dealer Network, we're also fleet managers, parts suppliers, capital procurement specialists and trainers. You'll find that when it comes to service, we do it all.

Hyster® Fleet Services

As much as we'd like for your entire fleet to be Hyster, we know that's not always the case. But just because you also operate other brands doesn't mean we can't manage your lift truck maintenance and replacement plan. We can analyze your current fleet or provide summary of your fleet history and a cost-effective proposal for replacement and scheduled maintenance of all your vehicles. Once this initial review is complete, we'll continue to monitor your fleet to ensure it's performing optimally.

UNISOURCE™ Parts Program

In addition to providing fleet management for a variety of brands, we can also serve as your source of parts for all your lift trucks. With the Hyster UNISOURCE parts and service program, we offer approximately 2 million part number crosses for most brands of materials handling and other in-plant mobile equipment. UNISOURCE also has remanufactured parts that provide the same quality and guarantee but at a lower price. And we can deliver parts to you in less than 24 hours, any day of the week. How's that for convenience?

Rental Products

At Hyster Company, we're always looking for ways to help you keep your productivity up. Through the Hyster Dealer Network, you can access rental equipment for the times when leasing or buying isn't a practical option. Your local Hyster Dealer has access to over 14,000 units that are available for short- or long-term rental. Whether you need one truck to substitute for a vehicle that's being serviced or several lift trucks to accommodate seasonal changes in your business, we'll help you maintain output in a cost-effective manner.

Hyster® Capital

We know that financing new additions to your fleet can sometimes be challenging. That's why your Hyster Dealer has a long list of ways for you to fund your purchase. We are skilled in arranging solutions for special financing requirements, taking the difficulties out of buying the equipment you need. Whether you purchase or lease a new or used lift truck, Hyster Capital offers better service and competitive rates, ensuring you receive the value you deserve.

Special Products

Engineering Department (SPED)

In a perfect world, every application could be handled with a standard lift truck. However, in the real world, different materials require different handling. That's why Hyster Company's Special Products Engineering Department works with you to customize* your lift trucks. From strobe lights to specially made forks, SPED can provide you with the tools you require to get the job done right.

* May be subject to an additional charge. Contact your local authorized Hyster Dealer for more information.

Automated Warehouse Solutions

As society's technological capabilities advance, we strive to find practical applications. One of our most recent innovations in that pursuit is our development of automated warehouse solutions. We can help you determine if your operation would benefit from this type of system, which improves inventory accuracy, warehouse productivity and safety records, as it reduces maintenance and overtime.

Operator and Service Training

Hyster Company recognizes that proper training is a key element of a profitable company. That's why your local authorized Hyster Dealer offers a training program for your lift truck operators as well as those who maintain your vehicles. Proper education in running and servicing lift trucks cuts down on the number of repairs and risk of injuries due to accidents while increasing productivity. All of our trainers are professionals with experience in materials handling.



FLEET SERVICES



HYSTER CAPITAL

A Division of NMFG Financial Services, Inc.



Hyster Company
P.O. Box 7006
Greenville, North Carolina
27835-7006
Part No. B60Z/BTG
7/2009 Litho in U.S.A.

Visit us online at www.hysterusa.com or call us at 1-800-HYSTER-1.

Hyster and  are registered trademarks of Hyster Company. UNISOURCE is a trademark of Hyster Company. Hyster products are subject to change without notice.

©2008 Hyster Company. All rights reserved.

