



**Walkie/Rider Motorized Hand Pallet Truck**

**B80Z<sup>AC</sup> Series**



*The Safe Choice*

## PRODUCTIVITY:

Why work harder when you can work smarter? The B80Z<sup>AC</sup> hand pallet truck helps you do just that with features that let you move more loads with less effort.

- Optional double and triple pallet fork lengths allow operators to move more product at once.
- Truck features a full six inches of lift height for easy maneuverability over uneven floor surfaces and across dock plates.
- The short head length and design of the control handle allows for the best turning radius and right angle stacking capabilities in its class.
- Pace setting travel speeds allow more loads to be moved per hour.
- A high performance hydraulic system, coupled with the advanced pallet entry/exit system, produces outstanding cycle times.
- Optional Coast Control with Side Glide feature enhances operator performance and productivity while increasing low level order picking efficiency.
  - Coast Control available with Advanced activation or Manual activation.
- Power Assist Steer option helps operators move heavy loads through tight turns and crowded loading areas with ease.
- Operator selectable, programmable performance modes enable the truck to be tailored to the application or operator skill level.
- AC traction controller provides improved torque, increased travel speeds and allows smoother acceleration and directional changes.
- Extended Shift Feature:
  - With Extended Shift “ON”, truck performance is tailored with “energy efficiency” in mind, allowing the truck to operate longer between battery charges.
  - With Extended Shift “OFF”, parameters are adjusted with high performance in mind, allowing quicker acceleration and directional changes, for faster cycle times resulting in increased throughput and productivity.

## DEPENDABILITY:

Hyster Company has a 75-year history of engineering and manufacturing some of the most reliable and dependable lift trucks on the market. The durable B80Z<sup>AC</sup> was designed to be long lasting.

- CANbus communication system significantly reduces the number of wires required in the electrical system, and links the control handle, display, controller and Power Assist Steer (option) together enhancing overall truck reliability.
- Steel reinforced control handle is durable, impact resistant and easy to service.
- Electro-mechanical brake has no linkage to adjust and maintain.
- Electronic horn provides high volume, consistent operation and long life.
- AC traction transistor controller eliminates motor brushes and directional contactors, creating a very reliable product with minimal maintenance requirements.
- Integrated transistor pump control provides a “soft start” feature by eliminating the high in-rush current associated with contactors and, therefore, extends the service life of the pump motor.
- The AC system uses less energy than SEM systems, increasing overall truck performance while decreasing battery charge intervals.

## ERGONOMICS:

The superior ergonomic design of the new B80Z<sup>AC</sup> walkie/rider product means greater comfort for your operator. A comfortable operator is a more productive operator.

- Unique control handle design features left hand and right hand controls which allow fingertip control of lift/lower, travel and the horn functions with either hand.
- Side Glide with Coast Control feature eliminates climbing on/off during quick pick applications.
- Activation buttons for the optional Advanced Coast Control are conveniently positioned on each side of the steer handle for easy, effortless thumb operation from either side of the truck.
- 1-inch thick rubber floor mat absorbs shock from uneven floor surfaces or dock plates enhancing operator comfort when riding.
- Power Assist Steer option requires less effort from the operator, reducing fatigue and enhancing truck maneuverability.
- Padded and contoured steady rest provides a soft and comfortable grab point, increasing operator stability while riding.
- Low step height provides quick and easy on/off access for operator, reducing fatigue during the work shift.
- Large operator area provides comfortable and productive positioning.
- Ergonomically angled handgrips and contoured control handle provides a comfortable grip and enhances truck positioning capabilities.



## COST OF OPERATION:

One of the best ways to increase your profits is to keep your equipment costs down. The Hyster B80Z<sup>AC</sup> is designed to operate at the peak of efficiency so you can take your money straight to the bank.

- Four application/environmental packages are available to ensure you have the right truck for the job:
  - Standard Construction: +32° F to +120° F
  - Cooler/Freezer Package: 0° F to +120° F
  - **subZERO** Freezer Package: -40° F to +120° F
  - Extreme Corrosion/Wash Down Package
- Operator selectable, programmable performance modes that allow operators to tailor the truck to meet their preferred working style or to meet application requirements.
- CANbus communication system, coupled with easy motor and component access, simplifies the electrical system and increases diagnostic capabilities, which reduces down time.
- All wire harness connectors feature double sealed industrial type connections, which prevent moisture and other contaminants from entering the connector.
- The B80Z<sup>AC</sup> is ETACC compatible and features on-board software interfacing, eliminating specialty tools and handsets.
- The electro-mechanical brake system has no linkage to maintain or adjust.
- Auto Deceleration System (ADS) utilizes regenerative braking, which significantly reduces brake wear, extending brake component life and reducing downtime.
- The design of the optional Advanced Coast Control saves valuable seconds each time the operator engages or disengages the system resulting in more pick time.

## SERVICEABILITY:

What's the trick to keeping your pallet trucks up and running? Hyster Company's legendary serviceability features. All B80Z<sup>AC</sup> components requiring regular maintenance are designed for easy access and simplified servicing, getting your operators back to work quicker than ever.

- Transistor Motor Control eliminates directional and lift pump contactors.
- AC traction motor has no brushes and commutator to maintain/replace.
- Backlit dash display allows easy reading in low/minimal light conditions.
- Electrical compartment cover is secured by spring clip retention, allowing removal of cover without tools.
- The electro-mechanical brake has no service requirements.
- Hall-effect throttle control is a non-contact device, eliminating wear components and requiring no mechanical adjustments.
- Lube fittings and serviceable bushings are used at all pivot points, reducing component wear and extending component life.
- Translucent hydraulic reservoir provides quick and easy fluid level check.
- Stationary traction motor design eliminates power cable flexing and potential for loose power wire connections.
- On-board diagnostic capability allows for quick troubleshooting, increasing truck uptime.
- CANbus communication system simplifies truck wiring and reduces the number of wires required.

## THESE HYSTER® TRUCKS TAKE IT TO EXTREMES

For some, combining industry leading productivity and dependability with world-renowned serviceability in a pallet truck series would be enough. At Hyster Company that's just the beginning.

When Hyster® engineers designed the B80Z<sup>AC</sup> pallet truck series, they knew some of our customers would be putting it to work in harsh environments. That is why they not only designed the Cooler/Freezer and **subZERO** Packages, but they also developed an Extreme Corrosion/Wash Down Package as well.

The B80Z<sup>AC</sup> Extreme Corrosion/Wash Down Package provides extra protection for applications that require frequent wash downs, or that expose the pallet truck to potentially corrosive agents. So how is this extra protection provided? By using a galvanized steel frame, lift linkage, battery well and fork weldment. Where other lift trucks would rust and require additional cleaning and repainting, the B80Z<sup>AC</sup> with the Extreme Corrosion/Wash Down Package keeps on trucking.

The frame is completely galvanized and corrosion resistant, eliminating damage from airborne contaminants in the form of paint or rust flakes. This package not only protects your investment, it eliminates periodic cleaning, scraping and repainting, resulting in more time to move product.



# RAISING THE STANDARD FOR LIFT TRUCKS

**Floor Mat:** 1-inch thick rubber floor mat absorbs shock from uneven floor surfaces or dock plates enhancing operator comfort when riding.

**Control Handle:** The short head length and design of the control handle allows for the best turning radius and right angle stacking capabilities in its class.

**Steady Rest:** Padded and contoured to provide a soft and comfortable grab point, increasing operator stability while riding.

**Load Backrest:** Available in 48", 60", and 72" heights (bolt-on or pivoting).

**Lift Height:** Truck features a full six inches of lift height for easy maneuverability over uneven floor surfaces and across dock plates.

**Brake:** Electro-mechanical brake has no linkage to adjust and maintain.

## STANDARD EQUIPMENT

- 48" Long Forks
- 27" Fork Spread
- Standard Construction Operating Temperatures: +32° F to +120° F
- Smooth Polyurethane Drive Tire – 90 Durometer – 12"x 4.5"
- Single Polyurethane Load Wheels – 3.25" x 6.5"
  - Four Bearings per Wheel
- Standard Duty Casters – Polyurethane Wheels
- Manual Steering
- Key Ignition Switch
- 24 Volt Transistor Control Electrical System
- AC Traction Motor (Brushless)
- Operator Selectable, Programmable Performance Modes
- Integrated "Soft Start" Transistor Lift Pump Control
- ADS (Auto Deceleration System) w/Regenerative Braking
- Extended Shift Feature
- 31.25" x 13.4" Open Battery Compartment
- Electro-Mechanical Park Brake
- UL Classification Type "E"
- Electronic Horn
- Impact Resistant, Steel Reinforced, Ergonomic Control Handle
- Pallet Exit Rollers/Entry Skids
- Knock-Out Load Wheel Axles
- 6" Lift Height
- Boxed Fork Construction with Reinforced Fork Tips
- Flush Pallet Stop
- Long Life Lift Linkage
- Multi-Function Display
  - Battery State of Charge
  - Hour Meter
  - Low Battery Lift Interrupt
  - Performance Mode Indicator
  - Fault Indicator
- On-Board Software
  - Test and Diagnose
  - No Handset Required
  - Password Protected

## OPTIONAL EQUIPMENT

- Power Assist Steer
- Battery Rollers
- Convenience Tray (Load Backrest Mounted or Battery Mounted)
- RF Terminal Power Supply – 24 Volt
- Audible Alarm
- Visible Alarm – Pole Mounted Amber Strobe
- UL Classification Type "EE"
- Advanced Coast Control with Side Glide
- Manual Coast Control with Side Glide
- Casters
  - Heavy Duty
  - Heavy Duty with SEALED Wheel and Swivel Bearings
- Fork Lengths
  - 36" Long Forks
  - 42" Long Forks
  - 60" Long Forks
  - 84" Long Forks
  - 93" Long Forks
  - 96" Long Forks
  - 144" Long Forks
- Drive Tire
  - Soft Polyurethane – 80 Durometer
  - Siped Polyurethane – 90 Durometer
- Load Wheels
  - Single and Dual
  - 2 Bearing and 4 Bearing
  - Standard Bearing and SEALED Bearing
- Load Backrest
  - 48" High (Pivoting or Bolt-on)
  - 60" High (Pivoting or Bolt-on)
  - 72" High (Bolt-on)
- Application/Environmental Construction
  - Cooler/Freezer Package
    - Operating Temperatures: 0° F to +120° F
  - subZERO Freezer Package
    - Operating Temperatures: -40° F to +120° F
  - Extreme Corrosion/Wash Down Package
    - Operating Temperatures: 0° F to +120° F
    - Includes SEALED Load Wheel Bearings
    - Includes Heavy Duty Casters with SEALED Wheel and Swivel Bearings

# B80Z<sup>AC</sup>

Hyster Company has the answer to all your pallet truck challenges in the B80Z<sup>AC</sup> series. These 8,000-lb. capacity units feature optional double and triple fork lengths as well as four application/environmental packages, designed to accommodate your individual requirements, all while delivering advanced productivity, exceptional dependability and superior serviceability – making the B80Z<sup>AC</sup> one of the best values available in motorized walkie/rider models. Want a hard-working, reliable, easy-to-operate motorized pallet truck? You want the B80Z<sup>AC</sup>.

# DIMENSIONS

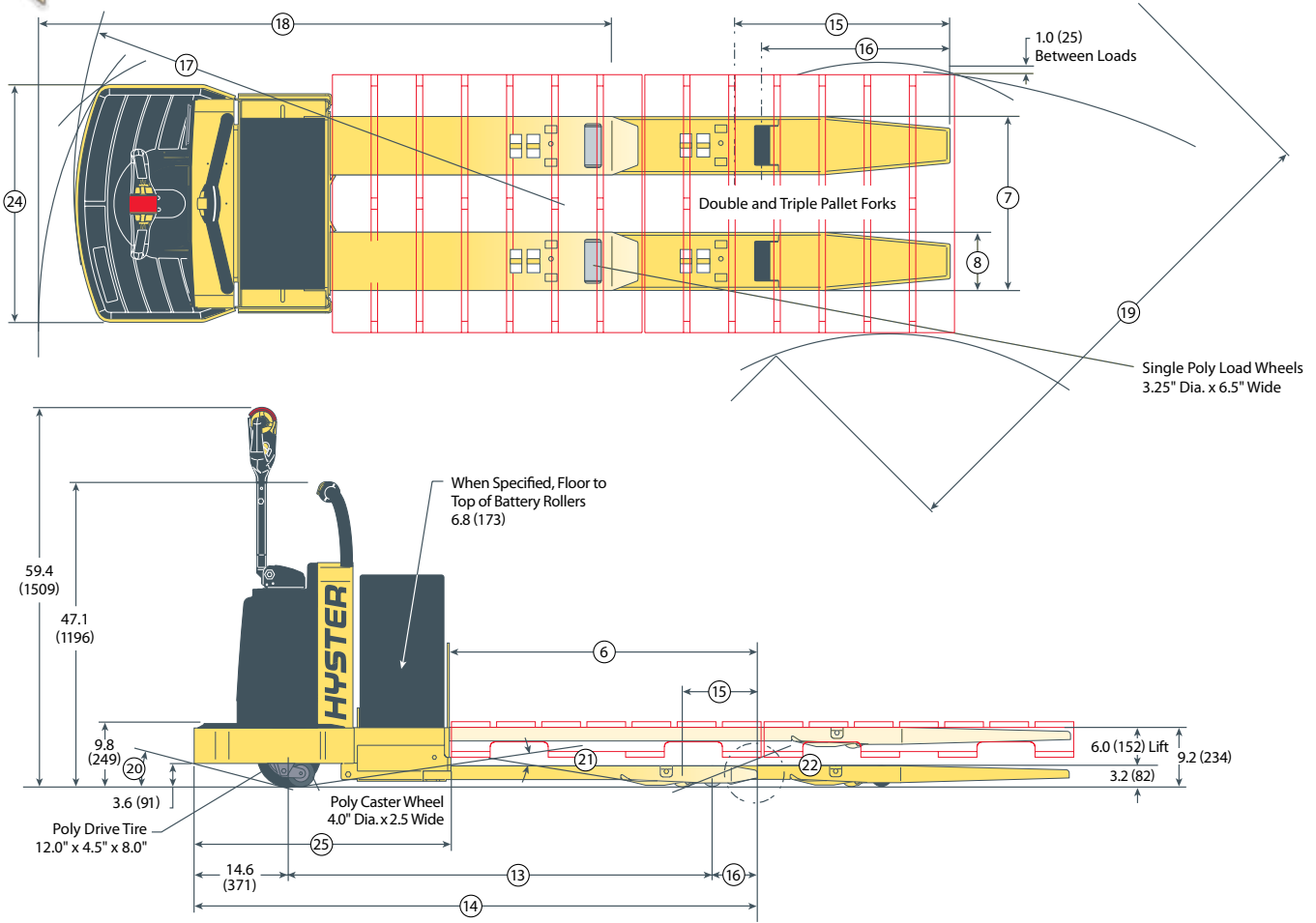

Circled dimensions correspond to the line numbers on the tabulated chart inside the Technical Guide. Dimensions are in inches (millimeters).

### GMA Pallet - Standard Dimensions

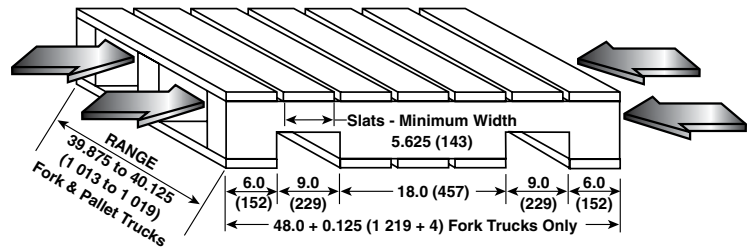

BATTERY SPECIFICATIONS							
Number of Cells	Cell Size	Plates per Cell	Capacity 6 Hr Rate amp hr (kwh)	Battery Dimensions			Weight lb. (kg)
				"X" in. (mm)	"Y" in. (mm)	"Z" in. (mm)	
12	75	7	225 (5.2)	25.7 (652)	8.8 (224)	23.3 (592)	540 (245)
12	85	7	255 (6.0)	25.7 (652)	8.8 (224)	23.3 (592)	570 (259)
12	75	11	375 (8.7)	26.5 (673)	13.0 (330)	23.3 (592)	825 (374)
12	85	11	425 (9.9)	26.5 (673)	13.0 (330)	23.3 (592)	865 (392)
12	75	13	450 (10.5)	30.9 (785)	13.0 (330)	23.3 (592)	987 (448)
12	85	13	510 (11.9)	30.9 (785)	13.0 (330)	23.3 (592)	1035 (469)
12	100	13	600 (14.0)	30.9 (785)	13.0 (330)	26.2 (665)	1140 (517)
12	125	13	750 (17.6)	30.9 (785)	13.0 (330)	31.0 (787)	1450 (658)

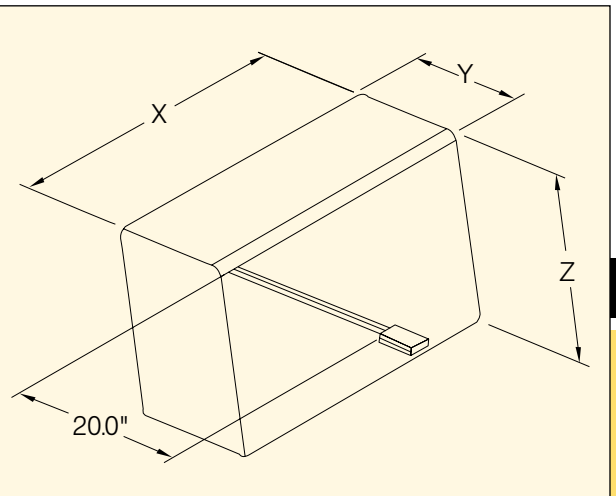

Battery Connector: 175 Amp, Red • Battery Lead: Length 20" (508 mm), Position "B", 1/0 AWG

# SPECIFICATIONS

7

GENERAL	1		HYSTER COMPANY				HYSTER COMPANY					
	2	Model Designation		B80Z <sup>AC</sup>				B80Z <sup>AC</sup>				
3	Power		Battery - 24 Volt				Battery - 24 Volt					
4	Operation		Walk / Stand Ride				Walk / Stand Ride					
5	Rated Capacity		8000 (3629)				8000 (3629)					
6	Fork Length	Nominal	in (mm)	36 (914)	42 (1067)	48 (1219)	60 (1524)	84 (2134)	93 (2362)	96 (2438)	144 (3658)	
	Fork Length	Actual	in (mm)	35.75 (908)	41.75 (1060)	47.75 (1213)	59.75 (1518)	83.75 (2127)	92.75 (2356)	95.75 (2432)	143.75 (3651)	
7	Fork Overall Width		in (mm)	27.0 (686)	27.0 (686)	27.0 (686)	27.0 (686)	27.9 (709)	27.9 (709)	27.9 (709)	27.9 (709)	
8	Fork Width - Individual Fork		in (mm)	9.1 (231)	9.1 (231)	9.1 (231)	9.1 (231)	10.0 (254)	10.0 (254)	10.0 (254)	10.0 (254)	
9	Load Distance (Face of Forks to Center of Load Wheel)	Lowered	in (mm)	28.75 (730)	34.75 (883)	40.75 (1035)	52.75 (1340)	61.85 (1571)	61.85 (1571)	61.85 (1571)	109.85 (2790)	
10	Truck Weight	Without Battery	No Load	lb (kg)	1280 (581)	1307 (593)	1334 (605)	1388 (630)	1436 (651)	1463 (664)	1490 (676)	1706 (774)
	Axle Loading - Drive	Static with Max. Wt. Battery	Rated Load	lb (kg)	2739 (1242)	3128 (1419)	3447 (1564)	3982 (1806)	3576 (1622)	3181 (1443)	2976 (1350)	4714 (2138)
11	Axle Loading - Drive	Static with Max. Wt. Battery	No Load	lb (kg)	1770 (803)	1841 (835)	1903 (863)	2045 (928)	2132 (967)	2117 (960)	2102 (953)	2572 (1167)
	Axle Loading - Load Wheel	Static with Max. Wt. Battery	Rated Load	lb (kg)	7991 (3625)	7629 (3460)	7337 (3328)	6856 (3110)	7310 (3316)	7732 (3507)	7964 (3612)	6442 (2922)
12	Axle Loading - Load Wheel		No Load	lb (kg)	960 (435)	916 (415)	881 (400)	793 (360)	754 (342)	796 (361)	838 (380)	584 (265)
	Wheelbase - No Load Backrest or with Pivoting Load Backrest	Raised	in (mm)	51.2 (1300)	57.2 (1453)	63.2 (1605)	75.2 (1910)	84.2 (2139)	84.2 (2139)	84.2 (2139)	132.2 (3358)	
13	Wheelbase - No Load Backrest or with Pivoting Load Backrest	Lowered	in (mm)	55.8 (1417)	61.8 (1570)	67.8 (1722)	79.8 (2027)	88.8 (2256)	88.8 (2256)	88.8 (2256)	136.8 (3475)	
	Wheelbase - With Bolt-On Load Backrest	Raised	in (mm)	53.2 (1351)	59.2 (1504)	65.2 (1656)	77.2 (1961)	86.2 (2189)	86.2 (2189)	86.2 (2189)	134.2 (3409)	
14	Wheelbase - With Bolt-On Load Backrest	Lowered	in (mm)	57.8 (1468)	63.8 (1621)	69.8 (1773)	81.8 (2078)	90.8 (2306)	90.8 (2306)	90.8 (2306)	138.8 (3526)	
	Overall Length - No Load Backrest or with Pivoting Load Backrest		in (mm)	77.3 (1963)	83.3 (2116)	89.3 (2268)	101.3 (2573)	125.3 (3183)	134.3 (3411)	137.3 (3487)	185.3 (4707)	
15	Overall Length - With Bolt-On Load Backrest		in (mm)	79.3 (2014)	85.3 (2167)	91.3 (2319)	103.3 (2624)	127.3 (3233)	136.3 (3462)	139.3 (3538)	187.3 (4757)	
	Center of Load Wheel to Tip of Forks	Raised	in (mm)	11.7 (297)	11.7 (297)	11.7 (297)	11.7 (297)	26.5 (673)	35.5 (902)	38.5 (978)	38.5 (978)	
16	Center of Load Wheel to Tip of Forks	Lowered	in (mm)	7.0 (178)	7.0 (178)	7.0 (178)	7.0 (178)	21.9 (556)	30.9 (785)	33.9 (861)	33.9 (861)	
	Outside Turning Radius - No Load Backrest or with Pivoting Load Backrest	Raised	in (mm)	65.6 (1666)	71.6 (1819)	77.6 (1971)	89.6 (2276)	98.6 (2504)	98.6 (2504)	98.6 (2504)	149.6 (3800)	
17	Outside Turning Radius - No Load Backrest or with Pivoting Load Backrest	Lowered	in (mm)	70.3 (1786)	76.3 (1938)	82.3 (2090)	94.3 (2395)	103.3 (2624)	103.3 (2624)	103.3 (2624)	154.3 (3919)	
	Outside Turning Radius - With Bolt-On Load Backrest	Raised	in (mm)	67.6 (1717)	73.6 (1869)	79.6 (2022)	91.6 (2327)	100.6 (2555)	100.6 (2555)	100.6 (2555)	151.6 (3851)	
18	Outside Turning Radius - With Bolt-On Load Backrest	Lowered	in (mm)	72.3 (1836)	78.3 (1989)	84.3 (2141)	96.3 (2446)	105.3 (2675)	105.3 (2675)	105.3 (2675)	156.3 (3970)	
	Right Angle Stack - No Load Backrest or with Pivoting Load Backrest	Raised	in (mm)	80.3 (2040)	85.7 (2177)	91.0 (2311)	101.7 (2583)	129.1 (3279)	137.4 (3490)	140.1 (3559)	186.2 (4729)	
19	Right Angle Stack - With Bolt-On Load Backrest	Raised	in (mm)	82.1 (2085)	87.4 (2220)	92.8 (2357)	103.5 (2629)	130.9 (3325)	139.2 (3536)	142.0 (3607)	188.1 (4778)	
	Equal Intersecting Aisle - No Load Backrest or with Pivoting Load Backrest	Raised	in (mm)	62.9 (1598)	66.0 (1676)	69.1 (1755)	75.3 (1913)	80.6 (2047)	82.0 (2083)	82.6 (2098)	106.6 (2708)	
20	Equal Intersecting Aisle - With Bolt-On Load Backrest	Raised	in (mm)	64.4 (1636)	67.6 (1717)	70.7 (1796)	76.9 (1953)	81.7 (2075)	83.7 (2126)	84.1 (2136)	107.4 (2728)	
	Grade Clearance	Chassis	%	27	27	27	27	27	27	27	27	
21	Grade Clearance	Ctr of Wheelbase	%	38	33	30	24	22	22	22	14	
	Grade Clearance	Forks	%	39	39	39	39	17	13	11	11	
22	Lift Height - Top of Fork	Lowered Ht / Raised Ht / Total Lift	in (mm)	3.2 / 9.2 / 6.0 (81 / 234 / 152)				3.2 / 9.2 / 6.0 (81 / 234 / 152)				
	Truck Overall Width		in (mm)	36.9 (937)				36.9 (937)				
23	Chassis Length (Length of Face to Forks)		in (mm)	41.5 (1054)				41.5 (1054)				
	Battery Compartment - Length x Width x Height	Standard / with Battery Rollers	in (mm)	31.25 x 13.4 x OPEN (793 X 340 X OPEN)				31.25 x 13.4 x OPEN (793 X 340 X OPEN)				
24	Travel Speed - Chassis First	No Load/Rated Load	mph (kph)	9.0 / 6.2 (14.5 / 10.0)				9.0 / 6.2 (14.5 / 10.0)				
	Travel Speed - Forks First	No Load/Rated Load	mph (kph)	6.0 / 5.2 (9.7 / 8.4)				6.0 / 5.2 (9.7 / 8.4)				
25	Drive Control	Type		AC				AC				
	Service Brake	Type		Electro-Mechanical				Electro-Mechanical				
26	Drive Tire	Size / Type (Number of Wheels)	in	12.0 x 4.5 x 8.0 / Poly (1)				12.0 x 4.5 x 8.0 / Poly (1)				
	Load Wheel	Size / Type (Number of Wheels)	in	3.25 x 6.5 / Poly (2)				3.25 x 6.5 / Poly (2)				
27	Caster Wheel	Size / Type (Number of Wheels)	in	4.0 x 2.5 / Poly - Spring Loaded (2)				4.0 x 2.5 / Poly - Spring Loaded (2)				

Above specifications, unless otherwise listed, are for a standard truck without optional equipment.  
 Right Angle Stack and Equal Intersecting Aisle are calculated using a 40" wide pallet.  
 Grade Clearance measured to the bottom of the pallet with forks in a raised position.

**CERTIFICATION:** These Hyster® lift trucks meet design specifications of Part II ANSI B56.1-1969, as required by OSHA Section 1910.178(a)(2) and also comply with Part III ANSI B56.1-revision in effect at time of manufacture. Certification of compliance with the applicable ANSI standards appears on the lift truck.  
**NOTE:** Performance specifications / ratings are for truck equipped as described under Standard Equipment in this Technical Guide. Performance specifications are affected by the condition of the vehicle and how it is equipped, as well as by the nature and condition of the operating area. Specifications are subject to change and the proposed application should be discussed with your authorized Hyster Dealer.

## It's not just about the lift trucks.

Any company worth its weight knows success has just as much to do with the support before and after the sale as the sale itself. We pride ourselves on being more than just a lift truck manufacturer. Through our Dealer Network, we're also fleet managers, parts suppliers, capital procurement specialists and trainers. You'll find that when it comes to service, we do it all.

## Hyster® Fleet Services

As much as we'd like for your entire fleet to be Hyster, we know that's not always the case. But just because you also operate other brands doesn't mean we can't manage your lift truck maintenance and replacement plan. We can analyze your current fleet or provide summary of your fleet history and a cost-effective proposal for replacement and scheduled maintenance of all your vehicles. Once this initial review is complete, we'll continue to monitor your fleet to ensure it's performing optimally.

## UNISOURCE™ Parts Program

In addition to providing fleet management for a variety of brands, we can also serve as your source of parts for all your lift trucks. With the Hyster UNISOURCE parts and service program, we offer approximately 2 million part number crosses for most brands of materials handling and other in-plant mobile equipment. UNISOURCE also has remanufactured parts that provide the same quality and guarantee but at a lower price. And we can deliver parts to you in less than 24 hours, any day of the week. How's that for convenience?

## Rental Products

At Hyster Company, we're always looking for ways to help you keep your productivity up. Through the Hyster Dealer Network, you can access rental equipment for the times when leasing or buying isn't a practical option. Your local Hyster Dealer has access to over 14,000 units that are available for short- or long-term rental. Whether you need one truck to substitute for a vehicle that's being serviced or several lift trucks to accommodate seasonal changes in your business, we'll help you maintain output in a cost-effective manner.

## Hyster® Capital

We know that financing new additions to your fleet can sometimes be challenging. That's why your Hyster Dealer has a long list of ways for you to fund your purchase. We are skilled in arranging solutions for special financing requirements, taking the difficulties out of buying the equipment you need. Whether you purchase or lease a new or used lift truck, Hyster Capital offers better service and competitive rates, ensuring you receive the value you deserve.

## Special Products

### Engineering Department (SPED)

In a perfect world, every application could be handled with a standard lift truck. However, in the real world, different materials require different handling. That's why Hyster Company's Special Products Engineering Department works with you to customize\* your lift trucks. From strobe lights to specially made forks, SPED can provide you with the tools you require to get the job done right.

\* May be subject to an additional charge. Contact your local authorized Hyster Dealer for more information.

## Automated Warehouse Solutions

As society's technological capabilities advance, we strive to find practical applications. One of our most recent innovations in that pursuit is our development of automated warehouse solutions. We can help you determine if your operation would benefit from this type of system, which improves inventory accuracy, warehouse productivity and safety records, as it reduces maintenance and overtime.

## Operator and Service Training

Hyster Company recognizes that proper training is a key element of a profitable company. That's why your local authorized Hyster Dealer offers a training program for your lift truck operators as well as those who maintain your vehicles. Proper education in running and servicing lift trucks cuts down on the number of repairs and risk of injuries due to accidents while increasing productivity. All of our trainers are professionals with experience in materials handling.



FLEET SERVICES



HYSTER CAPITAL

A Division of NMHG Financial Services, Inc.



Hyster Company  
P.O. Box 7006  
Greenville, North Carolina  
27835-7006  
Part No. B80Z/BTG  
7/2009 Litho in U.S.A.

Visit us online at [www.hysteramericas.com](http://www.hysteramericas.com)  
or call us at 1-800-HYSTER-1.

Hyster and  are registered trademarks of Hyster Company. UNISOURCE is a trademark of Hyster Company. Hyster products are subject to change without notice.

©2008 Hyster Company. All rights reserved.

