



STRONG PARTNERS. TOUGH TRUCKS.™

W40Z SERIES

Walkie Motorized, Hand, Low Lift Pallet Truck





THE HYSTER® ADVANTAGE

MANEUVERABILITY:

The Hyster® W40Z is redefining navigation in small spaces. The attributes of this general-purpose Walkie greatly enhance maneuverability on crowded loading docks and inside narrow trailers.

- Standard W40Z creep speed function allows truck to run with the control handle in the full “up” position, giving operators better visibility by placing them closer to loads.
- Fingertip control of all truck functions with either hand aids steering and pallet positioning in tight spots.
- Freighter’s Special option offers shorter fork tips and a unique bumper profile, making loads easier to pin-wheel inside trailers.

PRODUCTIVITY:

It’s a simple fact of your business that you need to move your product quickly and efficiently with minimum downtime. The W40Z helps you do just that with several productivity-enhancing features.

- The Auto Deceleration System extends traction motor brush and brake life by automatically slowing the truck when the accelerator is released, translating to a longer life – and more time spent working.
- The solid state transistor controls significantly reduce the number of parts, maximizing uptime.
- Regular maintenance is simplified by a 40 percent reduction in electrical connections and easily identifiable wiring.
- The optional 48- or 60-inch load backrest extension maximizes load capabilities to increase efficiency.

EASE OF USE:

The superior ergonomic design of the W40Z makes operators noticeably more efficient.

- The control handle design allows the operator to command all truck functions at their fingertips, no matter which hand they use.
- Ergonomically angled handgrips and a contoured handle design provide comfortable operator positioning and protection for fingers and knuckles during operation.
- The handle features a direction throttle control actuator that provides 30° rotation in either direction, making it easy to actuate through the full range of motion.
- Wrap around traction reversing button provides a large area of contact.



◀ The standard creep speed feature greatly increases maneuverability by allowing the W40Z to operate with the handle in the full upright position. With the Freighter’s Special option, the steer handle is kept away from the side of the trailer during pin-wheeling.

W40Z

Volume is key in any warehousing or retailing application. Hyster Company helps you boost yours with the W40Z Walkie pallet truck. Its exceptional maneuverability stems from legendary Hyster ergonomics and performance innovations. Features such as creep speed and fingertip control put the power to be productive in your operators’ hands. The Cooler / Freezer Package makes the W40Z an excellent tool in environments with operating temperatures ranging from 0° to 120° F. And the greater maneuverability of the Freighter’s Special makes it possible to place two additional pallets in a trailer – quickly and efficiently. So, when it comes to raising your throughput, the Hyster W40Z is the clear choice.



FREIGHTER'S SPECIAL

Great Things Come in Small Packages.

Hyster engineers are always looking for ways to make your job easier. That's why they've designed the Freighter's Special, an option exclusive to the Hyster W40Z. The Freighter's Special shares the same superior ergonomic and enhanced serviceability features as the standard W40Z, but it also has a few perks all its own.

Hyster Company has shortened the fork tip length of the W40Z by two inches and redesigned the bumper to provide a tighter right angle turn for easier right angle stacking and equal aisle placement. The fully boxed fork tips improve angled pallet entry, allowing the forks to straddle the centerboard when

pin-wheeling and entering the pallet at a right angle.

Operators will appreciate the creep/turtle speed feature that allows the W40Z to be operated with the handle in the "up" position. Offering better visibility, operators are able to get closer to their loads. Placing pallets becomes more precise, minimizing the likelihood of product damage.

The combination of shorter fork tips and unique bumper profile allows operators to load two additional pallets per trailer, boosting their productivity and your throughput.

All this means that when space is at a premium, the W40Z Freighter's Special is a perfect fit.

Leave it to Hyster Company to find a solution to meet your materials handling needs.

REAR BUMPER



BOLT-ON STABILITY TABS



SHORT FORK TIPS



FEATURES



STANDARD

24 Volt

SEM Transistor Control with Integrated Hoist Control

48" Long Forks

27" Fork Spread

Low Battery Lift Interrupt

Lift Motor Time-out at Full Height

Standard Construction

Operating Temperatures:
+32° to +120° F

Flush Pallet Stop

Electromagnetic Park Brake with Service Override

Regenerative Braking

Press-on Rubber Drive Tire (9" x 5")

Impact-Resistant, Ergonomically Designed, Bottom Mount Control Handle with Gas Spring Return

Direction Reversing Switch

Creep Speed "Turtle" Button

Three User Selectable Performance Modes

OPTIONAL

Fork Lengths

36" Long Forks

42" Long Forks

Fork Spread

18" Fork Spread

22" Fork Spread

Note: Fork dimensions listed (length, spread, width) are nominal. See specifications page for actual dimensions.

Optional Construction

Cooler / Freezer Package:
0° to +120° F

Load Backrest

48" High (Bolt-on)*

60" High (Bolt-on)*

**Cowl Mount 8.1" Battery Compartment Mount 9.1", increases truck length by 2"*

Freighter's Special

45.2" "Freighter's Special" Fork Configuration

Redesigned Bumper Profile

Battery

12-85-7 Industrial Battery with 28.0" x 9.1" Battery Compartment, increases truck length by 1"

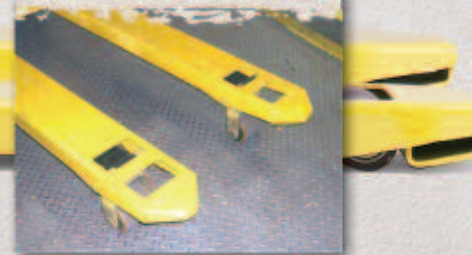

Trucks shown with optional equipment.

DIMENSIONS

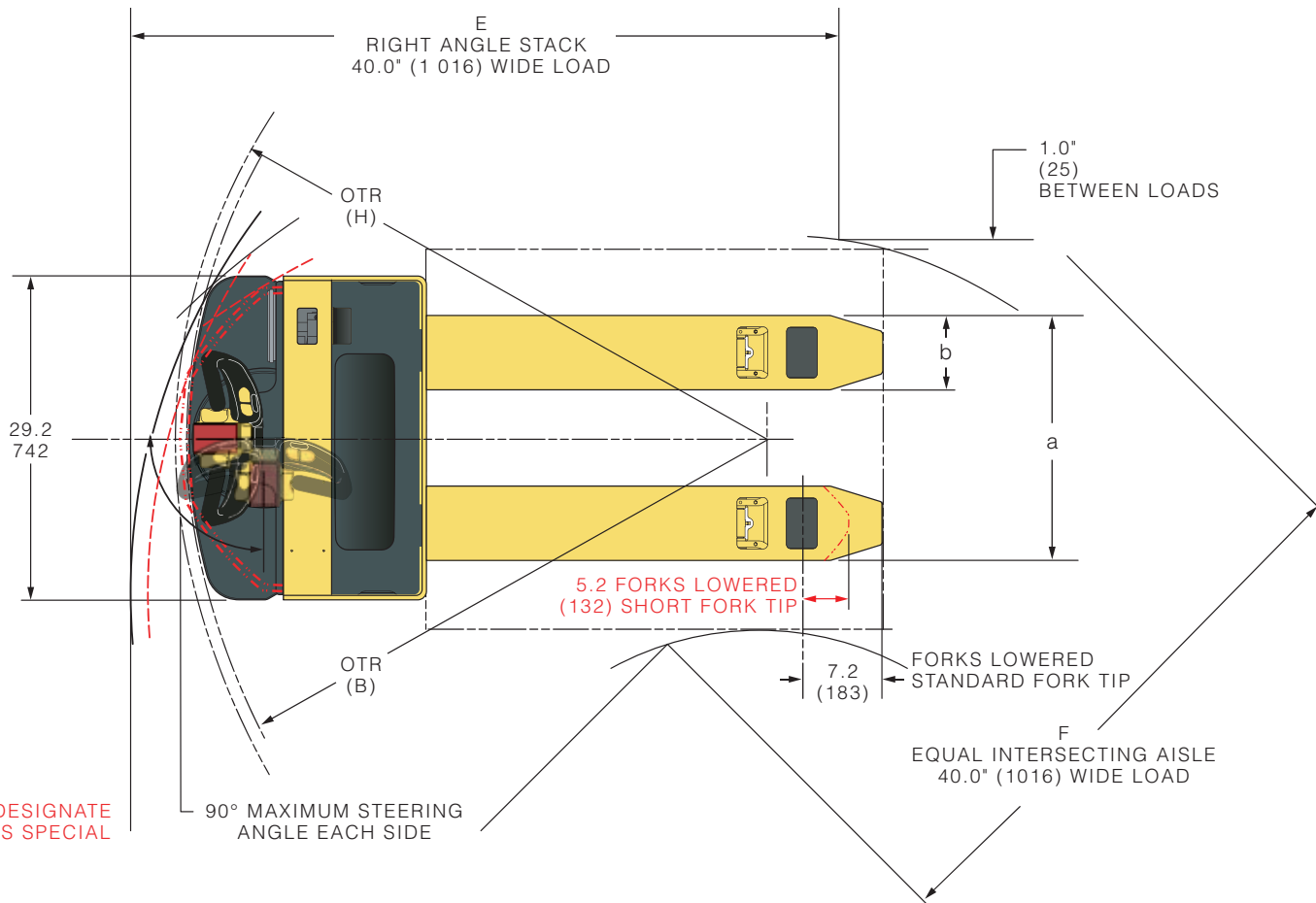
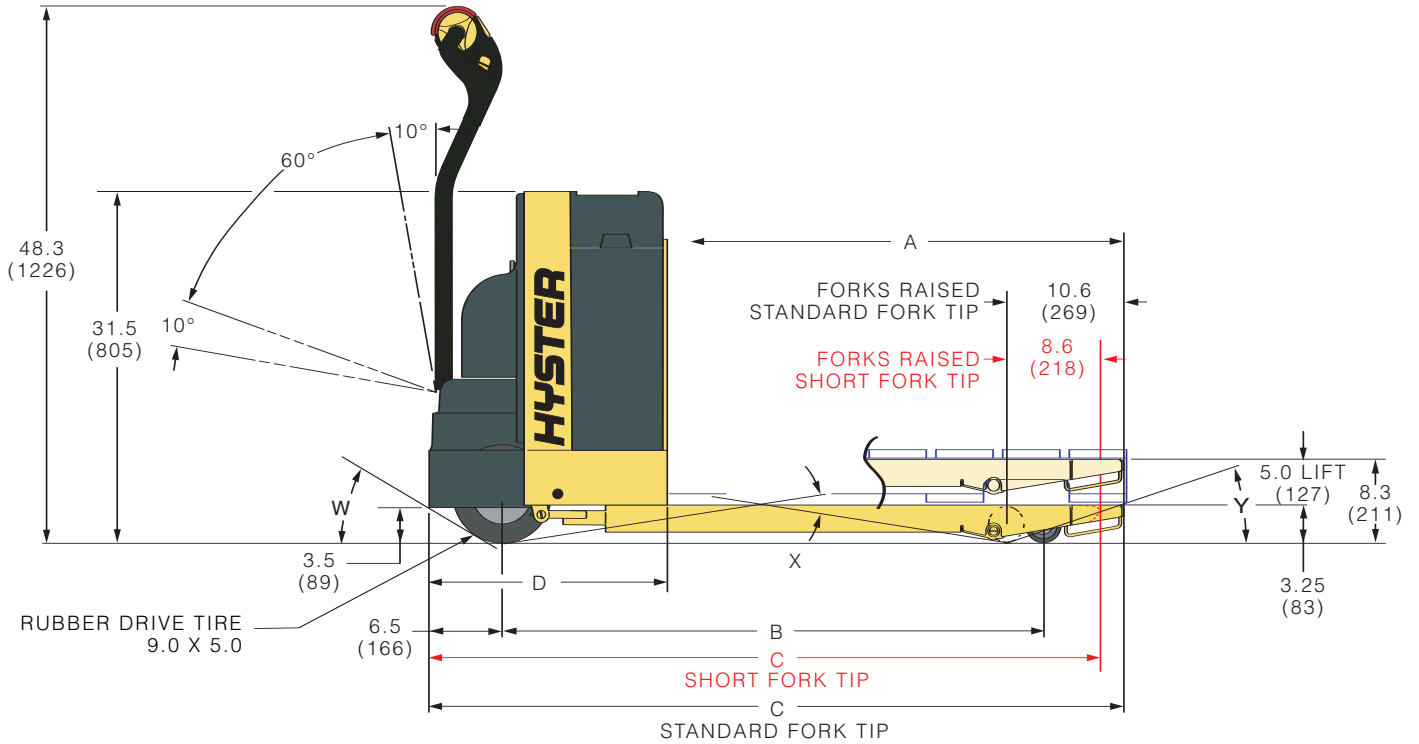

RED LINES DESIGNATE FREIGHTER'S SPECIAL

SPECIFICATIONS



TRUCK DIMENSIONS: SINGLE LOAD WHEELS, 24 VOLT, 28.5" x 8.1" BATTERY COMPARTMENT

DIMENSION	DESCRIPTION		FORK POSITION	DIMENSIONS IN INCHES (MILLIMETERS)			
				W40Z Standard Fork Tip			W40Z Freighter's Special
	Fork Type			W40Z Standard Fork Tip			W40Z Freighter's Special
A	Fork Length	Nominal	–	36 (900)	42 (1050)	48 (1200)	48 (1200)
		Actual	–	35.4 (899)	41.3 (1049)	47.2 (1199)	45.2 (1148)
B	Wheel Base		Raised	39.7 (1008)	45.6 (1158)	51.5 (1308)	51.5 (1308)
			Lowered	43.1 (1095)	49.0 (1245)	54.9 (1395)	54.9 (1395)
C	Overall Length		–	56.8 (1442)	62.7 (1592)	68.6 (1742)	66.6 (1691)
D	Chassis Length		–	21.4 (544)	21.4 (544)	21.4 (544)	21.4 (544)
OTR (b)	Outside Turning Radius (bumper)		Raised	46.2 (1174)	52.1 (1324)	58.0 (1474)	58.0 (1474)
			Lowered	49.6 (1261)	55.6 (1411)	61.5 (1561)	61.5 (1561)
OTR (h)	Outside Turning Radius (handle)		Raised	47.5 (1206)	53.4 (1356)	59.3 (1506)	59.3 (1506)
			Lowered	50.9 (1293)	56.8 (1443)	62.7 (1593)	62.7 (1593)
E	Right Angle Stack (aisle)		Raised	61.5 (1562)	66.5 (1689)	71.3 (1810)	69.0 (1753)
F	Equal Intersecting Aisle		–	52.5 (1334)	54.9 (1394)	57.5 (1460)	56.0 (1422)
W	% Grade Clearance ¹		Raised	67%	67%	67%	67%
X	% Grade Clearance ¹		Raised	40%	34%	30%	30%
Y	% Grade Clearance ¹		Raised	33%	33%	33%	33%
	Right Angle Stack* (truck)		Raised	–	–	100.4 (2550)	95.0 (2413)

¹ Measured to the bottom of a GMA approved pallet on the forks while they are in the raised position.

* Length is measured side to side of truck. Width is measured front to back on the truck.

FORK DIMENSIONS

DIMENSION	DESCRIPTION		DIMENSIONS IN INCHES (MILLIMETERS)		
a	Fork OAW (Over All Width)	Nominal	18 (460)	22 (560)	27 (670)
		Actual	18.1 (460)	22.0 (560)	26.4 (670)
b	Fork Width	Nominal	7.0 (170)	7.0 (170)	7.0 (170)
		Actual	6.9 (170)	6.9 (170)	6.9 (170)

PERFORMANCE



BATTERY SPECIFICATIONS AND WEIGHTS

BATTERY	CAPACITY AMP-HOURS	(6 HR RATE) KWH	BATTERY CONNECTOR	LENGTH	WIDTH	HEIGHT	NOMINAL WEIGHT
Standard Battery Pack with 12A Charger	158	4.0	X type-175 Amp Red	28.4" (721 mm)	7.9" (201 mm)	23.9" (607 mm)	310 lbs. (141 kg)
GNB PalletPro® Battery Pack with 25A Charger ^s	195	4.4	175 Amp Red	27.3" (693 mm)	7.5" (191 mm)	26.4" (671 mm)	375 lbs. (170 kg)
12-85-7 Industrial Battery	255	6.0	175 Amp Red	25.7" (653 mm)	8.8" (224 mm)	23.3" (592 mm)	570 lbs. (259 kg)

Battery cable length 20.0 inch (508 mm), 1/0 gauge leads, B position. Truck weight, total approx. with battery power pack - 850 lbs. (386 kg) ^s GNB PalletPro® battery pack requires a .5 in. (12 mm) thick backplate spacer for proper positioning. Standard battery well 28.5" (724 mm) x 8.1" (206 mm) x open. Optional battery well 28.0" (712 mm) x 9.1" (231 mm) x open. Please note battery size is limited by the rounded corners of battery compartment. Maximum battery width and length dimensions cannot be used in conjunction with each other. Please contact your local Hyster Dealer for more information and details.

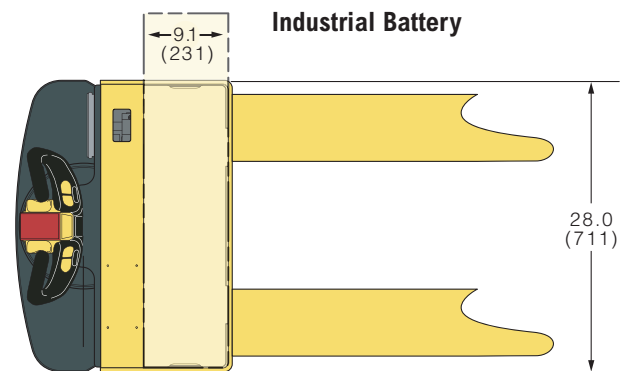
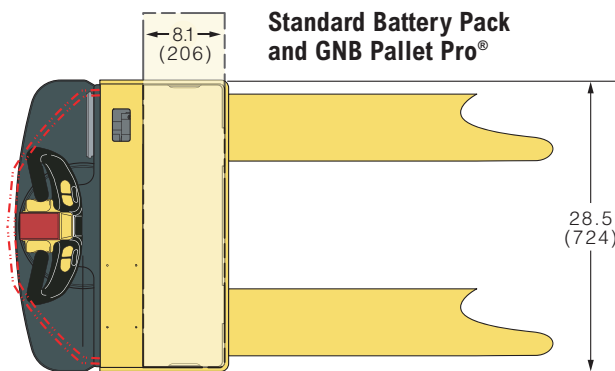

TRAVEL SPEEDS (USER SELECTABLE PERFORMANCE MODES)

MODE 1			
	No Load	4000 lbs. (1818 kg)	
	Speed	Speed	
mph	3.4	2.7	
kph	5.5	4.3	

MODE 2			
	No Load	4000 lbs. (1818 kg)	
	Speed	Speed	
mph	3.6	3.2	
kph	5.8	5.1	

MODE 3			
	No Load	4000 lbs. (1818 kg)	
	Speed	Speed	
mph	3.8	3.4	
kph	6.1	5.5	

24 Volt SEM Traction Control: 9" x 5" Rubber Drive Tire, Single Poly Load Wheels **Industrial Battery:** 600 lbs. (273 kg); 300 amp-hours

LIFT / LOWER INFORMATION

24 VOLT			
Lift Time	Sec	No Load	3.0
	Sec	4000 lbs.	4.0
Lowering Time	Sec	No Load	2.0
	Sec	4000 lbs.	1.0

GMA PALLET – STANDARD DIMENSIONS

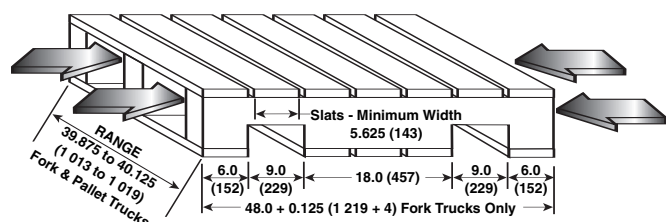



FLEET SERVICES

It's not just about the lift trucks.

Any company worth its weight knows success has just as much to do with the support before and after the sale as the sale itself. We pride ourselves on being more than just a lift truck manufacturer. Through our Dealer Network, we're also fleet managers, parts suppliers, capital procurement specialists and trainers. You'll find that when it comes to service, there's not much we don't do.

Hyster® Fleet Services

As much as we'd like for your entire fleet to be Hyster, we know that's not always the case. But just because you also operate other brands doesn't mean we can't manage your lift truck maintenance and replacement plan. We can analyze your current fleet or provide a summary of your fleet history and a cost-effective proposal for replacement and scheduled maintenance of all your vehicles. Once this initial review is complete, we'll continue to monitor your fleet to ensure it's performing optimally.

UNISOURCE™ Parts Program

In addition to providing fleet management for a variety of brands, we can also serve as your source of parts for all your lift trucks. With the Hyster UNISOURCE parts and service program, we offer approximately 2 million part number crosses for most brands of materials handling and other in-plant mobile equipment. UNISOURCE also has remanufactured parts that provide the same quality and guarantee but at a lower price. And we can deliver parts to you in less than 24 hours, any day of the week. How's that for convenience?



Rental Products

At Hyster Company, we're always looking for ways to help you keep your productivity up. Through the Hyster Dealer Network, you can access rental equipment for the times when leasing or buying isn't a practical option. Your local Hyster Dealer has access to over 14,000 units that are available for short- or long-term rental. Whether you need one truck to substitute for a vehicle that's being serviced or several lift trucks to accommodate seasonal changes in your business, we'll help you maintain output in a cost-effective manner.

Hyster® Capital

We know that financing new additions to your fleet can sometimes be challenging. That's why your Hyster Dealer has a long list of ways for you to fund your purchase. We are skilled in arranging solutions for special financing requirements, taking the difficulties out of buying the equipment you need. Whether you purchase or lease a new or used lift truck, Hyster Capital offers flexible service and competitive rates, ensuring you receive the value you deserve.

Special Products Engineering Department (SPED)

In a perfect world, every application could be handled with a standard lift truck. However, in the real world, different materials require different handling. That's why Hyster Company's Special Products Engineering Department works with you to customize* your lift trucks. From strobe lights to specially made forks, SPED can provide you with the tools you require to get the job done right.

* May be subject to an additional charge. Contact your local Authorized Hyster Dealer for more information.



HYSTER CAPITAL

A Division of NMHG Financial Services, Inc.

Automated Warehouse Solutions

As society's technological capabilities advance, we strive to find practical applications. One of our most recent innovations in that pursuit is our development of automated warehouse solutions. We can help you determine if your operation would benefit from this type of system, which improves inventory accuracy, warehouse productivity and safety records, as it reduces maintenance and overtime.

Operator and Service Training

Hyster Company recognizes that proper training is a key element of a profitable company. That's why your local Authorized Hyster Dealer offers a training program for your lift truck operators as well as those who maintain your vehicles. Proper education in running and servicing lift trucks cuts down on the number of repairs and risk of injuries due to accidents while increasing productivity. All of our trainers are professionals with experience in materials handling.



Hyster Company
P.O. Box 7006
Greenville, North Carolina
27835-7006
Part No. W40Z/BTG
1/2006 Litho in U.S.A.

Visit us online at www.hysterusa.com or call us at 1-800-HYSTER-1.

Hyster and  are registered trademarks of Hyster Company.  is a trademark of Hyster Company. Hyster products are subject to change without notice.
GNB PalletPro is a registered trademark of its respective company.
©2006 Hyster Company. All rights reserved.

