



High Capacity Forklift Trucks

H550-700HD/S Series



H550-700HD/S SERIES

Hyster Company has a long history of designing and building high capacity forklift trucks. The Hyster® H550-700HD/S offers best-in-class operator comfort; fast handling, reliable, proven components; high productivity; and represents an excellent return on investment. If your operation needs a rugged, versatile lift truck, the Hyster H550-700HD/S series is your performance solution.

Like all Hyster lift trucks, the H550-700HD/S models can be customized with just about any optional attachment you'll need to pick up, grab or lift your loads. These big truck models are ideally suited for a wide variety of applications such as steel manufacturing, and sea ports for general cargo or moving and stacking loaded and unloaded containers.



Key standard features of the new H550-700HD/S include:

- Cummins® QSC 8.3L TurboDiesel engine with 230 peak HP, EPA Tier compliant
- Spicer® Off-Highway TE-17 3-Speed Autoshifting Transmission
- Planetary Drive Axle with Oil-Immersed Wet Disc Brakes
- Load-sensing "Power-on-Demand" Hydraulic System
- Open Operator Compartment with Integral Overhead Guard, featuring:
 - Seat-Side Hydraulic Control Levers
 - Multifunction Display Panel
 - Interior and Exterior Wide-Angle Mirrors
 - Telescoping & Tilting Steering Column
 - Floormat
 - 24-12V DC converter
- Mechanical, Full Suspension, Vinyl Seat with Integrated Adjustable Armrest and Seatbelt
- Sy-Klone® Spinner Type Heavy Duty Air Intake Pre-Cleaner
- 24V Electrical System with 70 Amp Alternator
- Manual Tilt Operator Compartment for Service Access
- Halogen Light Kit
- Visible and Audible Alarms
- Steer Wheel Nut Protection



A Hydrostatic Steer Axle

The Hyster designed, 'sandwich' type steer axle with transverse, double-acting hydraulic cylinder, tapered roller spindle bearings and non-adjustable tie rods provide maximum durability and superior steering control for easy maneuvering.

B Counterweight

The superior design of the downward sloping counterweight allows for excellent rearward visibility. Lights are recessed in the counterweight for maximum protection.

C Ease of Service

Gull-wing hood doors feature gas springs along with a tilting cab to allow for more extensive maintenance work.

D High Performance Hydraulics

The new Power-on-Demand load-sensing hydraulic system delivers hydraulic fluid only when it is needed. This means fewer engine RPMs to do the work, less heat created, and increased efficiency. The results are higher fuel economy, reduced noise, longer component life and less heat generated.

E Cooling System

An extensive cooling system consists of 4 coolers for all truck systems, and ensures low operating temperatures for dependable operation.

F Operator Compartment

The operator compartment and controls were ergonomically designed to help reduce operator fatigue and improve productivity. The operator compartment is large and uncluttered, allowing the operator ample room for auxiliary options. It features a spacious environment, an adjustable suspension seat with integrated armrest and low effort controls, 4-way adjustable steering wheel, and power-assisted steering and brakes. The cab's structural design creates excellent all-around visibility.



Trucks shown with optional equipment.

H550-700HD/S

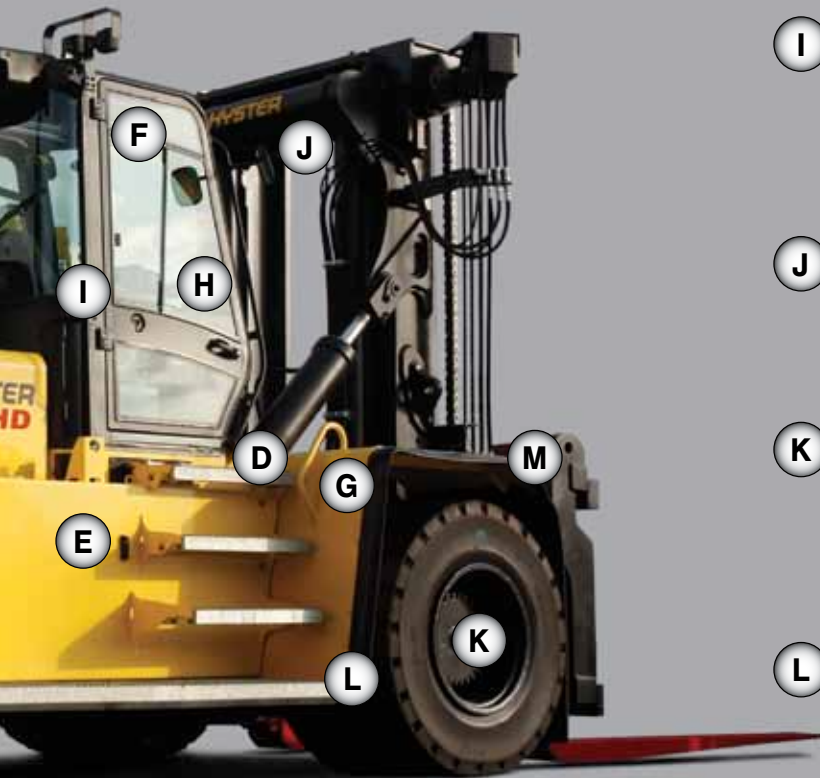

G Grab Handles

Three grab handles and four steps, featuring low step heights, provide easy ingress and egress for the operator.

H Tilt Steering Column

Fully adjustable tilt steer column, with telescoping reach, accommodates operators easily. A directional control lever is conveniently located on the tilt column for ease of direction or gear change.

I Hydraulic Controls

Two levers offer control of the lift and tilt of the mast, while additional levers or switches are offered for control of other hydraulic functions. As an alternative, Hyster offers a joystick option for control of hydraulic functions.

J Vista Mast

The mast has been widened for even better forward visibility. The hoist cylinders are located behind the mast channels, and the chains have been moved outboard, outside of the visibility window.

K Heavy Duty Drive Axle

The drive axle features a heavy-duty ductile iron housing for durability. Four bolts per side secure the drive axle to the chassis. The axle assembly is a full floating design, which allows the truck's weight to be supported by the axle housing, not the shafts.

L Oil-Immersed Wet Disc Brakes

Wet disc brakes provide excellent stopping power and extremely long service life. Brakes are completely sealed from water and dirt making them ready for your harshest environments.

M Carriage

Equipped with a pin type carriage with mechanical fork locks as standard; the H550HD/S has a 122" wide carriage, and the H620-700HD/S has a 129" wide carriage. Additional sideshifting and fork positioning carriage options are available.

Decrease Downtime

Approximately 70% of industrial lift truck downtime results from problems with the powertrain, brakes, electrical systems, cooling or hydraulic system. With the H550-700HD/S, design advances have led to improvements in reliability and up-time.

Rugged Powertrain

- ECM (electronic control module) onboard computer controls monitors and protects the engine to maximize uptime.
- ACP 200 electronic transmission controller monitors the transmission and communicates back to the ECM for optimum dependability.
- Oil-Immersed Wet Disc Brakes provide excellent stopping power and extremely long service life. Brakes are completely sealed from water and dirt making them ready for your harshest environments.

Industrial Strength Electronics

- CANbus communications, nonmechanical sensors and switches, and IP67 rated sealed connections mean reduced electrical problems.
- Particular attention has been given to the routing and clamping of the wire harnesses to ensure they are not exposed to any heat, oil contamination or chaffing.
- 24 volt electrical system requires fewer amps, which means cooler temperatures and longer life. Delco® alternator has an output of 70 amps.
- Electronic lockout prevents engagement of the starter while engine is running.

Exceptional Cooling

- The cooling system consists of (from top to bottom) a charge air cooler, engine cooler, a hydraulic oil cooler and a transmission oil cooler, horizontally arranged and mounted on isolators. All units are separately serviceable and removable.
- The cooling system uses high performance, triangular waved, non-louvered fins with a large face area matched to the fan airflow characteristics for optimum efficiency. The radiator fin density minimizes plugging due to airborne contaminants.
- The cooling system uses a large 762mm (30-inch) diameter 9-blade puller type fan running at a low speed and optimized fan shroud to achieve high cooling efficiency and low noise.
- The flip up rear cover is held by two gas shocks and facilitates easy access for cleaning the radiator compartment.



- A separate coolant expansion tank incorporates a level switch to provide the operator with an early warning of low coolant condition.
- A triple hydraulic system cooler, for the brakes and hydraulic system, is ideally mounted at the front of the truck. The fans are activated as needed by temperature switches. Cooling system maintains normal system operating even in high ambient temperatures (120°).

Hassle-Free Hydraulics

- Leak-free O-ring face seal fittings, used throughout the truck, reduce leaks for enhanced reliability.
- A 3400 psi lift hydraulic system allows the use of small hydraulic lines and components which increases operating efficiency and may improve fuel economy. Tilt and auxiliaries have 2900 psi relief in all valve variations.
- Hydraulic control valve sections provide fine-tuned metering of hydraulic functions.
 - Lift and tilt functions are proportional controlled.
 - Auxiliary functions are non-proportional controlled.
- Flexible wire-braid hoses and limited conventional steel hydraulic tubing are used to simplify the hydraulic plumbing. These hydraulic lines are carefully routed and clamped to extend service life and simplify service access.
- A 10-micron high-performance in-tank filtration system captures 99.5% of hydraulic system debris, significantly extending component life. The filter may be serviced without opening the hood.
- Smart placement of the control valve and hydraulic lines away from heat sources reduces operating temperature, extending the life of seals and hoses for enhanced reliability.

Lowering operating costs in all types of applications is what Hyster does best. The H550-700HD/S series is configured to provide improved efficiency, while enhancing reliability and superior serviceability to reduce your operating costs.

World-Class Efficiency

- Cummins QSC TurboDiesel engine features 500 hour service intervals.
- The hydraulic system features new load-sensing power-on-demand hydraulic pumps which only supply oil flow on demand. When the operating controls of the hoist or auxiliary functions are idle, no hydraulic oil is being displaced, which equals better fuel economy.
- The new hydraulic system provides lower oil operating temperatures, increased service intervals, and extended hydraulic component life.
- Rubber mounted hydraulic components, and leak-free O-ring face seal hydraulic system fittings dramatically improve uptime. Scheduled hydraulic periodic maintenance has been extended.
- The Engine Protection System monitors the cooling of the engine and transmission, oil pressures, and other system functions. This system will throttle back or shut off the engine, depending on the severity of the situation, to protect critical components.
- The Hyster® H550-700HD/S features oil-immersed wet disc brakes, which include a cooling and filtration system for long service life and dependable operation.
- Steer axle geometry has been redesigned to cut down on overall steer tire wear, which contributes to reducing the cost of ownership. Steer wheel nut protection is standard to avoid stud and nut damage on steer rims.
- Optional High Intensity Discharge lights are much brighter than halogen lights, and are rated for over 5000 hours of life, so they cost less per hour to operate compared to halogen lights.

Superior Serviceability

- Engine, transmission and hydraulic control modules continuously monitor truck operating conditions, reducing daily service checks and preventing major repairs.
- With the cab tilting to the side, the truck offers excellent serviceability access to all major components.
- Fully isolated from the cab, the gull wing hood concept provides excellent access to the engine for ease of servicing and daily checks. Downtime for maintenance is greatly reduced.



- With a fully tilting cabin, full running boards to work from, and easy opening hoods and covers, daily checks are easily accessed and performed.
- State-of-the-art onboard diagnostics reduce repair time and minimize expensive parts swapping.
- The cooling air duct is protected by a hinged cover that provides access to the entrance of the cooling system for cleaning and inspection. This cover is also large enough to remove and install a complete cooling system without hood removal.
- Coolant reservoir provides a convenient fluid level check and incorporates a level switch, to provide the operator with an early warning of low coolant condition. The filler neck tube design limits overfilling.
- Two-stage air intake system consists of a maintenance-free Sy-Klone® pre-cleaner mounted on the intake stack pipe and a Donaldson® heavy-duty single stage air cleaner assembly located inside the engine compartment.

Superior Operator Comfort

- To promote driver comfort and productivity, the operator compartment features a spacious work area, adjustable suspension seat, adjustable tilt steering wheel with telescoping reach, integrated adjustable armrest with low effort controls, and power assisted steering and brakes.
- The operator compartment is mounted on elastomeric rubber mounts isolating and minimizing the productivity robbing effects of road-born shocks and vibrations.
- Grab handles are provided to assist the operator in mounting and dismounting the unit.
- Curved front and rear tempered glass on the optional enclosed cab provides excellent visibility with no distortion. Retractable sunshades above the operator and at the rear window are standard with air conditioning and optional without.
- For heavy rain conditions, an optional H-pattern wiper with washer is available. The motor system is mounted below the cab to give unobstructed visibility.
- The cab features a high capacity heater with 6 duct outlets that provide all around comfort. A replaceable paper filter element filters the air from the outside. Recirculation and fresh air positions can be manually selected.
- Robust air conditioning system (optional) with 9 cooling duct outlets provides 37,500 btu/hour cooling capacity.



- Uncluttered, spacious floor is covered with a high-density rubber mat, decreasing sound inside the cab while increasing operator comfort to help reduce fatigue.
- The standard durable vinyl full-suspension seat is contoured to maximize your comfort. With an adjustable backrest angle separate from the seat, and armrests, your Hyster seat features weight sensitive adjustable spring rate. The seat's integral armrests/hip restraints provide an excellent arm or handhold to minimize torso strain when operating in a rearward position. All seats are fitted with an operator warning buzzer system that will sound if the parking brake is not applied.
- Standard seat-side hydraulic levers are mounted on the right armrest for effortless control.



Minimal Effort Operation

- The combination of a tilt and telescoping steering column and an adjustable full-suspension seat places your operator in the utmost comfort. Low effort, load-sensing power steering is standard equipment.
- Fully adjustable armrest with integrated hydraulic control functions provides exceptional operator comfort. Control levers or optional Joystick provide intuitive, effortless, precise control.
- The controls are provided with a seat-mounted armrest and are independently adjustable to the seat and maintain position relative to the seat when the seat is adjusted.
- State-of-the-art multifunction display panel with error code message facility for auto shift transmission and engine monitoring.

Increase Throughput and Sales Volume While Reducing Operating Costs

Productivity means moving more of your loads in less time with less cost. The Hyster® H550-700HD/S series sets the standard in productivity through performance, ergonomics (operator comfort and control), service, uptime and dependability.

Performance Choices For Your Application

- H550-700HD/S series is offered with two high output Tier 3 turbocharged and charge air cooled engines. Choose either a 230 peak hp or a whopping 264 peak hp engine. Coupled with a HD transmission, power-on-demand hydraulic system and a heavy duty cooling system, you can optimize productivity for your specific application.
- Cummins QSC 8.3L Turbo Diesel engine features electronically controlled high-pressure common-rail fuel system that controls combustion rate to improve fuel efficiency and reduce noise.
- Electronic automatic shifting is standard and is controlled by a new electronic transmission controller located within the cab console. The controller receives its signals from speed sensors on the transmission case providing optimal shifting points with smooth shifting characteristics.
- The APC 200 electronic transmission controller provides an adjustable option to limit maximum truck speed.
- When travelling in reverse and shifting forward, the controller will reverse directions only when the speed is below 3.1 mph and 1400 rpm engine speed. This protects the transmission and drive axle.
- The electronic control module guards the engine by de-rating engine torque and engine speeds or even stopping the engine in case the engine operates at conditions beyond the limits for coolant temperature, oil pressure and intake air temperature
- Trucks are equipped with Operator controlled hydraulic inching for precise vehicle position control.
- Large fuel tank capacities offer up to 24 hours of running time on a single tank. That means less downtime for refueling and increased productivity.
 - 96 Gallons (H550 – 700HD/S)
 - 81 Gallons (H550HDS)

Superior Operator Control

- Superior ergonomic features like more foot and leg room, standard lever or joystick hydraulic controls, infinitely adjustable steer column, integrated multifunction display, large steering wheel with spinner knob, and several choices of seats enable your operator to maximize productivity.
- A lower front cowl and rounded glass in the ComforCabll provides an unobstructed view ahead. In-line air-intake and exhaust pipes minimize rearward visibility obstructions. The rounded form of the hood, fenders and counterweight design allow you to see object sooner, dramatically increasing your rearward visibility.
- Visibility thru the mast has been improved by moving the chains and sheaves to the outside of the mast. Position of the cross members in the inner and outer mast sections was carefully chosen to give unobstructed visibility of the fork tips at ground level and various lifting heights.
- The new carriage design is wider and lower and available in many configurations to suit individual customer requirements. Increased visibility, over the top and through the carriages, provides a great range of fork tip visibility resulting in greater operator productivity throughout the day.

Superior Serviceability

- Easy access, daily service checks are quickly located and accessed. The integral multifunction display's onboard diagnostic capabilities and reduced service requirements significantly minimize service times to maximize uptime.
- The hydraulic oil tank features a gauge for oil level as well as magnetic drain plugs.
- The cab tilts to the right-hand side of the truck, powered by a manual or electric pump, giving you complete access to all of the major components.
- The combination of the tilting cab, gas-spring assisted gull-wing hood doors, and the rear opening hood provide excellent access for more extensive maintenance work.

DIMENSIONS

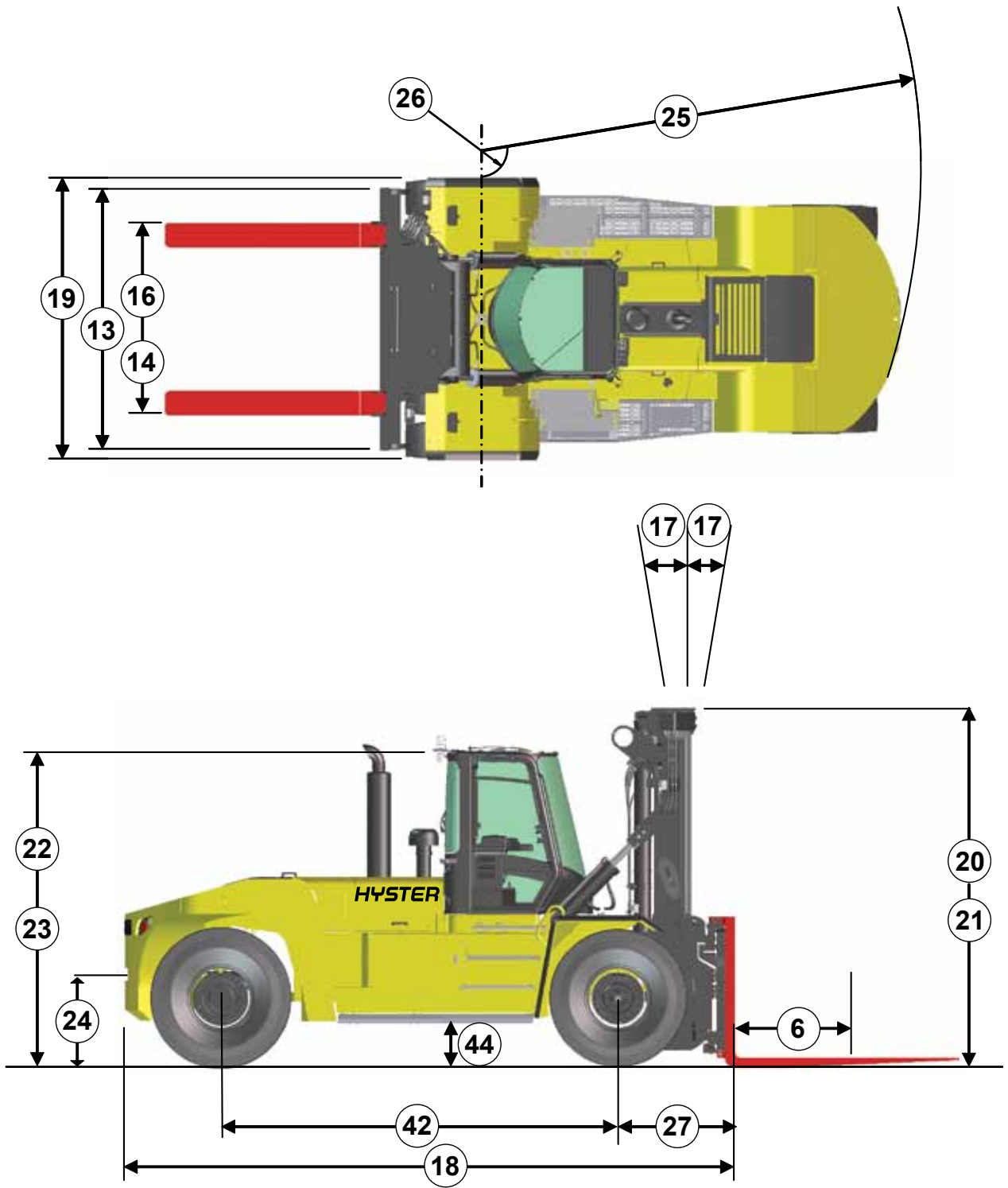

Dimensions correspond to the line numbers on the tabulated chart inside the Technical Guide. Dimensions are in inches (millimeters).

H550-620HD SPECIFICATIONS

GENERAL			Hyster Company	Hyster Company	Hyster Company	Hyster Company
	1	Manufacturer		Hyster Company	Hyster Company	Hyster Company
2	Model designation		H550HD	H550HD	H620HD	H620HD
3	Power Train - Engine Transmission		Cummins QSC 8.3 230hp	Cummins QSC 8.3 230hp	Cummins QSC 8.3 230hp	Cummins QSC 8.3 260hp
4	Transmission Type		Auto-Powershift	Auto-Powershift	Auto-Powershift	Auto-Powershift
5	Load capacity	lbs/kg	55,000 (25,000)	55,000 (25,000)	62,000 (28000)	62,000 (28000)
6	Load center	in (mm)	48 (1220)	48 (1220)	48 (1220)	48 (1220)
7	Drive Power Type: Gas, Diesel, LPG		Diesel	Diesel	Diesel	Diesel
8	Operation: Seated rider		Seated Rider	Seated Rider	Seated Rider	Seated Rider
9	Step Height (from ground to running board)	in (mm)	20.5 (520)	20.5 (520)	23.6 (600)	23.6 (600)
10	Step Height (btwn intermediate steps)	in (mm)	12.6 (320)	12.6 (320)	12.6 (320)	12.6 (320)
11	Tires: P=pneumatic, C=cushion, SC=supercushion		P	P	P	P
12	Number of wheels, front/rear (X = driven)		4X/2	4X/2	4X/2	4X/2
13	Fork carriage width - Standard Carriage	in (mm)	122 (3120)	122 (3120)	129 (3300)	129 (3300)
14	Fork Spacing - Std Carriage - Minimum Inside to inside edge	in (mm)	8.3 (211)	8.3 (211)	7.8 (198)	7.8 (198)
15	Fork dimensions	in (mm)	4.1x11.0x96 (105x280x2438)	4.1x11.0x96 (105x280x2438)	4.1 x 11.8 x 96 (105 x 300 x 2438)	4.1 x 11.8 x 96 (105 x 300 x 2438)
16	Fork Spacing - Std Carriage - Maximum outside to outside edge	in (mm)	116.9 (2970)	116.9 (2970)	122.4 (3108)	122.4 (3108)
17	Mast tilt, forward / back	degrees	6/10	6/10	6/10	6/10
18	Overall length (length to face of forks)	in (mm)	255 (6477)	255 (6477)	256 (6502)	256 (6502)
19	Overall width	in (mm)	127 (3225)	127 (3225)	133 (3378)	133 (3378)
20	Height of Standard mast, lowered (Rounded Up)	in (mm)	139 (3517)	139 (3517)	143 (3616)	143 (3616)
21	Height of mast, extended w/o load backrest (Rounded Up)	in (mm)	199 (5042)	199 (5042)	203 (5141)	203 (5141)
22	Height to top of Std. overhead guard (high) (Rounded Up)	in (mm)	133 (3381)	133 (3381)	136 (3451)	136 (3451)
23	Height to top of Cab w/o airco (Rounded Up)	in (mm)	135 (3424)	135 (3424)	138 (3495)	138 (3495)
23	Height to top of Cab w airco (Rounded Up)	in (mm)	136 (3459)	136 (3459)	139 (3530)	139 (3530)
24	Towing coupling height	in (mm)	37.8 (960)	37.8 (960)	40.6 (1031)	40.6 (1031)
25	Outer turning radius	in (mm)	244 (6184)	244 (6184)	244 (6197)	244 (6197)
26	Inner turning radius	in (mm)	40.1 (1018)	40.1 (1018)	34.8 (885)	34.8 (885)
27	Load distance (load face-ctr of wheel to face of forks- front overhang) 2 stg	in (mm)	43.7 (1109)	43.7 (1109)	45.1 (1140)	45.1 (1140)
28	Right angle stack (add length of load)	in (mm)	287 (7290)	287 (7290)	288 (7315)	288 (7315)
29	90° intersecting aisle (w/load W=96in, L=96in HD & W=72in, L=72in HDS) w/pin carriage	in (mm)	198 (5029)	198 (5029)	202 (5128)	202 (5128)
30	Travel speed (RL/NL)	mph (km/hr)	16/17 (25/27)	16/17 (25/27)	16/17 (25/27)	16/17 (25/27)
31	Lifting speed (2-stage) (RL/NL)	ft/min (m/sec)	59/69 (.30/.35)	59/69 (.30/.35)	49/57 (.25/.29)	49/57 (.25/.29)
32	Lowering speed (2-stage) (RL/NL)	ft/min (m/sec)	98/98 (.50/.50)	98/98 (.50/.50)	98/98 (.50/.50)	98/98 (.50/.50)
33	Maximum drawbar pull with load	lbs (kN)	39,482 (176)	44,938 (200)	39,671 (176)	45,211 (201)
34	Drawbar pull @ 1.0 mph or 1.6 km/h with load	lbs (kN)	31,531 (140)	36,125 (161)	31,597 (141)	36,263 (161)
35	Gradeability max with load	%	29%	34%	25%	28%
36	Gradeability @ 1.0 mph or 1.6 km/h with load	%	23%	27%	19%	22%
37	Unladen weight (w/ std equipment: mast, carriage, forks, etc.)	lb (kg)	80,647 (36591)	80,647 (36591)	95,054 (43128)	95,054 (43128)
38	Axle loading laden w/ std option configuration (Front/Rear)	lb (kg)	123,270 (55930) / 12,477 (5661)	123,270 (55930) / 12,477 (5661)	141,459 (64183) / 15,307 (6945)	141,459 (64183) / 15,307 (6945)
39	Axle loading unladen w/ std option configuration (Front/Rear)	lb (kg)	38,687 (17553) / 41,960 (19038)	38,687 (17553) / 41,960 (19038)	46,280 (20998) / 48,775 (22130)	46,280 (20998) / 48,775 (22130)
40	Tire size-front		14.00 x 24 28PR	14.00 x 24 28PR	16.00 x 25 28PR	16.00 x 25 28PR
41	Tire size-rear		14.00 x 24 28PR	14.00 x 24 28PR	16.00 x 25 28PR	16.00 x 25 28PR
42	Wheelbase	in (mm)	170 (4318)	170 (4318)	170 (4318)	170 (4318)
43	Ground clearance under mast, laden	in (mm)	11.8 (299)	11.8 (299)	11.8 (299)	11.8 (299)
44	Ground clearance at center of wheelbase	in (mm)	16.7 (424)	16.7 (424)	19.8 (503)	19.8 (503)
45	Brakes Service - Method of Control/Operation		Hydraulic/Foot	Hydraulic/Foot	Hydraulic/Foot	Hydraulic/Foot
46	Brakes Park - Method of Control/Operation		Mechanical/Hand	Mechanical/Hand	Mechanical/Hand	Mechanical/Hand
47	Battery Type		Maintenance Free	Maintenance Free	Maintenance Free	Maintenance Free
48	Battery Volts/Cold Cranking Amps		2x 12V/900	2x 12V/900	2x 12V/900	2x 12V/900
49	Engine manufacturer/type		Cummins Diesel	Cummins Diesel	Cummins Diesel	Cummins Diesel
50	Engine output, in accordance with ISO 1585	hp (kw)	230 (172)	264 (197)	230 (172)	264 (197)
51	Torque	ft/lb (N-m)	675 (915)	830 (1125)	675 (915)	830 (1125)
52	Number of cylinders/displacement	No./cc (ci)	6/8300 (506)	6/8300 (506)	6/8300 (506)	6/8300 (506)
53	Gear change type		Elec. Controlled Powershift	Elec. Controlled Powershift	Elec. Controlled Powershift	Elec. Controlled Powershift
54	Transmission: Number of speeds forward/reverse		3/3	3/3	3/3	3/3
55	Fuel Tank - Capacity (Gasoline- or Diesel-Powered Units Only)	gal (liters)	96 (364)	96 (364)	96 (364)	96 (364)
56	Working pressure for attachments	psi (bar)	3260 (225)	3260 (225)	3260 (225)	3260 (225)
57	Oil flow for attachments	gal/min (l/min)	18.5 (70)	18.5 (70)	18.5 (70)	18.5 (70)
58	Towing coupling type		Pin	Pin	Pin	Pin
59	Hydraulic Tank - capacity (drain & refill)	gal (liters)	72.4 (274)	72.4 (274)	72.4 (274)	72.4 (274)

CERTIFICATION: These Hyster® lift trucks meet design specifications of Part II ANSI B56.1-1969, as required by OSHA Section 1910.178(a)(2) and also comply with Part III ANSI B56.1-revision in effect at time of manufacture. Certification of compliance with the applicable ANSI standards appears on the lift truck.

NOTE: Performance specifications / ratings are for truck equipped as described under Standard Equipment in this Technical Guide. Performance specifications are affected by the condition of the vehicle and how it is equipped, as well as by the nature and condition of the operating area. Specifications are subject to change and the proposed application should be discussed with your authorized Hyster Company Dealer.

H650-700HD SPECIFICATIONS

GENERAL	1	Manufacturer	Hyster Company	Hyster Company	Hyster Company	Hyster Company		
	2	Model designation	H650HD	H650HD	H700HD	H700HD		
DIMENSIONS	3	Power Train - Engine Transmission	Cummins QSC 8.3 230hp	Cummins QSC 8.3 260hp	Cummins QSC 8.3 230hp	Cummins QSC 8.3 260hp		
	4	Transmission Type	Auto-Powershift	Auto-Powershift	Auto-Powershift	Auto-Powershift		
	5	Load capacity	lbs/kg	66,000 (30000)	66,000 (30000)	70,400 (32,000)	70,400 (32,000)	
	6	Load center	in (mm)	48 (1220)	48 (1220)	48 (1220)	48 (1220)	
	7	Drive Power Type: Gas, Diesel, LPG		Diesel	Diesel	Diesel	Diesel	
	8	Operation: Seated rider		Seated Rider	Seated Rider	Seated Rider	Seated Rider	
	9	Step Height (from ground to running board)	in (mm)	23.6 (600)	23.6 (600)	23.6 (600)	23.6 (600)	
	10	Step Height (btwn intermediate steps)	in (mm)	20.6 (600)	20.6 (600)	20.6 (600)	20.6 (600)	
	11	Tires: P=pneumatic, C=cushion, SC=super-cushion		P	P	P	P	
	12	Number of wheels, front/rear (X = driven)		4X/2	4X/2	4X/2	4X/2	
	PERFORMANCE	13	Fork carriage width - Standard Carriage	in (mm)	129 (3300)	129 (3300)	129 (3300)	129 (3300)
		14	Fork Spacing - Std Carriage - Minimum inside to inside edge	in (mm)	7.8 (198)	7.8 (198)	7.8 (198)	7.8 (198)
15		Fork dimensions	in (mm)	4.3 x 11.8 x 96 (110 x 300 x 2438)	4.3 x 11.8 x 96 (110 x 300 x 2438)	4.3 x 11.8 x 96 (110 x 300 x 2438)	4.3 x 11.8 x 96 (110 x 300 x 2438)	
16		Fork Spacing - Std Carriage - Maximum outside to outside edge	in (mm)	122.4 (3108)	122.4 (3108)	122.4 (3108)	122.4 (3108)	
17		Mast tilt, forward / back	degrees	6/10	6/10	6/10	6/10	
18		Overall length (length to face of forks)	in (mm)	256 (6502)	256 (6502)	276 (7010)	276 (7010)	
19		Overall width	in (mm)	133 (3378)	133 (3378)	133 (3378)	133 (3378)	
20		Height of Standard mast, lowered (Rounded Up)	in (mm)	143 (3616)	143 (3616)	143 (3616)	143 (3616)	
21		Height of mast, extended w/o load backrest (Rounded Up)	in (mm)	203 (5141)	203 (5141)	203 (5141)	203 (5141)	
22		Height to top of Std. overhead guard (high) (Rounded Up)	in (mm)	136 (3451)	136 (3451)	136 (3451)	136 (3451)	
23		Height to top of Cab w/o airco (Rounded Up)	in (mm)	138 (3495)	138 (3495)	138 (3495)	138 (3495)	
WT.		24	Height to top of Cab w airco (Rounded Up)	in (mm)	139 (3530)	139 (3530)	139 (3530)	139 (3530)
	25	Towing coupling height	in (mm)	40.6 (1031)	40.6 (1031)	40.6 (1031)	40.6 (1031)	
	26	Outer turning radius	in (mm)	244 (6197)	244 (6197)	270 (6858)	270 (6858)	
	27	Inner turning radius	in (mm)	34.8 (885)	34.8 (885)	51.5 (1309)	51.5 (1309)	
	28	Load distance (load face-ctr of wheel to face of forks-front overhang) 2 stg	in (mm)	45.1 (1140)	45.1 (1140)	45.1 (1140)	45.1 (1140)	
	29	Right angle stack (add length of load)	in (mm)	288 (7315)	288 (7315)	314 (8007)	314 (8007)	
	30	90° intersecting aisle (w/load W=96in, L=96in HD & W=72in, L=72in HDS) w/pin carriage	in (mm)	202 (5128)	202 (5128)	212 (5368)	212 (5368)	
	31	Travel speed (RL/NL)	mph (km/hr)	16/17 (25/27)	16/17 (25/27)	16/17 (25/27)	16/17 (25/27)	
	32	Lifting speed (2-stage) (RL/NL)	ft/min (m/sec)	49/57 (.25/.29)	49/57 (.25/.29)	49/57 (.25/.29)	49/57 (.25/.29)	
	33	Lowering speed (2-stage) (RL/NL)	ft/min (m/sec)	98/98 (.50/.50)	98/98 (.50/.50)	98/98 (.50/.50)	98/98 (.50/.50)	
	34	Maximum drawbar pull with load	lbs (kN)	39,671 (176)	45,211 (201)	39,575 (176)	45,115 (201)	
	35	Drawbar pull @ 1.0 mph or 1.6 km/h with load	lbs (kN)	31,597 (141)	36,263 (161)	31,502 (140)	36,167 (161)	
WHEELS & TIRES	36	Gradeability max with load	%	25%	28%	24%	27%	
	37	Gradeability @ 1.0 mph or 1.6 km/h with load	%	19%	22%	19%	22%	
	38	Unladen weight (w/ std equipment: mast, carriage, forks, etc.)	lb (kg)	96,385 (43732)	96,385 (43732)	95,546 (43351)	95,546 (43351)	
	39	Axle loading laden w/ std option configuration (Front/Rear)	lb (kg)	148,353 (67311) / 14,165 (6427)	148,353 (67311) / 14,165 (6427)	151,062 (68540) / 15,011 (6811)	151,062 (68540) / 15,011 (6811)	
	40	Axle loading unladen w/ std option configuration (Front/Rear)	lb (kg)	46,377 (21042) / 50,009 (22690)	46,377 (21042) / 50,009 (22690)	46,330 (21021) / 49,215 (22330)	46,330 (21021) / 49,215 (22330)	
	41	Tire size-front		16.00 x 25 28PR	16.00 x 25 28PR	16.00 x 25 28PR	16.00 x 25 28PR	
	42	Tire size-rear		16.00 x 25 28PR	16.00 x 25 28PR	16.00 x 25 28PR	16.00 x 25 28PR	
	43	Wheelbase	in (mm)	170 (4318)	170 (4318)	190 (4826)	190 (4826)	
	44	Ground clearance under mast, laden	in (mm)	11.8 (299)	11.8 (299)	11.8 (299)	11.8 (299)	
	45	Ground clearance at center of wheelbase	in (mm)	19.8 (503)	19.8 (503)	19.8 (503)	19.8 (503)	
	46	Brakes Service - Method of Control/Operation		Hydraulic/Foot	Hydraulic/Foot	Hydraulic/Foot	Hydraulic/Foot	
	47	Brakes Park - Method of Control/Operation		Mechanical/Hand	Mechanical/Hand	Mechanical/Hand	Mechanical/Hand	
TRANS. & POWER UNIT	48	Battery Type		Maintenance Free	Maintenance Free	Maintenance Free	Maintenance Free	
	49	Battery Volts/Cold Cranking Amps		2x 12V/900	2x 12V/900	2x 12V/900	2x 12V/900	
	50	Engine manufacturer/type		Cummins Diesel	Cummins Diesel	Cummins Diesel	Cummins Diesel	
	51	Engine output, in accordance with ISO1585	hp (kw)	230 (172)	264 (197)	230 (172)	264 (197)	
	52	Torque	ft/lb (N-m)	675 (915)	830 (1125)	675 (915)	830 (1125)	
	53	Number of cylinders/displacement	No./cc (ci)	6/8300 (506)	6/8300 (506)	6/8300 (506)	6/8300 (506)	
	54	Gear change type		Elec. Controlled Powershift	Elec. Controlled Powershift	Elec. Controlled Powershift	Elec. Controlled Powershift	
	55	Transmission: Number of speeds forward/reverse		3/3	3/3	3/3	3/3	
	56	Fuel Tank - Capacity (Gasoline- or Diesel-Powered Units Only)	gal (liters)	96 (364)	96 (364)	96 (364)	96 (364)	
	57	Working pressure for attachments	psi (bar)	3260 (225)	3260 (225)	3260 (225)	3260 (225)	
	58	Oil flow for attachments	gal/min (l/min)	18.5 (70)	18.5 (70)	18.5 (70)	18.5 (70)	
	59	Towing coupling type		Pin	Pin	Pin	Pin	
60	Hydraulic Tank - capacity (drain & refill)	gal (liters)	72.4 (274)	72.4 (274)	72.4 (274)	72.4 (274)		

CERTIFICATION: These Hyster® lift trucks meet design specifications of Part II ANSI B56.1-1969, as required by OSHA Section 1910.178(a)(2) and also comply with Part III ANSI B56.1-revision in effect at time of manufacture. Certification of compliance with the applicable ANSI standards appears on the lift truck.

NOTE: Performance specifications / ratings are for truck equipped as described under Standard Equipment in this Technical Guide. Performance specifications are affected by the condition of the vehicle and how it is equipped, as well as by the nature and condition of the operating area. Specifications are subject to change and the proposed application should be discussed with your authorized Hyster Company Dealer.

H550-650HDS SPECIFICATIONS

GENERAL			Hyster Company	Hyster Company	Hyster Company	Hyster Company
1	Manufacturer		Hyster Company	Hyster Company	Hyster Company	Hyster Company
2	Model designation		H550HDS	H550HDS	H650HDS	H650HDS
3	Power Train - Engine Transmission		Cummins QSC 8.3 230hp	Cummins QSC 8.3 260hp	Cummins QSC 8.3 230hp	Cummins QSC 8.3 260hp
4	Transmission Type		Auto-Powershift	Auto-Powershift	Auto-Powershift	Auto-Powershift
5	Load capacity	lbs/kg	55,000 (25,000)	55,000 (25,000)	65,000 (29483)	65,000 (29483)
6	Load center	in (mm)	36 (900)	36 (900)	36 (900)	36 (900)
7	Drive Power Type: Gas, Diesel, LPG		Diesel	Diesel	Diesel	Diesel
8	Operation: Seated rider		Seated Rider	Seated Rider	Seated Rider	Seated Rider
9	Step Height (from ground to running board)	in (mm)	20.5 (520)	20.5 (520)	23.6 (600)	23.6 (600)
10	Step Height (btwn intermediate steps)	in (mm)	12.6 (320)	12.6 (320)	12.6 (320)	12.6 (320)
11	Tires: P=pneumatic, C=cushion, SC=supercushion		P	P	P	P
12	Number of wheels, front/rear (X = driven)		4X/2	4X/2	4X/2	4X/2
13	Fork carriage width - Standard Carriage	in (mm)	122 (3120)	122 (3120)	129 (3300)	129 (3300)
14	Fork Spacing - Std Carriage - Minimum Inside to inside edge	in (mm)	8.3 (211)	8.3 (211)	7.8 (198)	7.8 (198)
15	Fork dimensions	in (mm)	4.1x11.0x96 (105x280x2438)	4.1x11.0x96 (105x280x2438)	4.3 x 11.8 x 96 (110 x 300 x 2438)	4.3 x 11.8 x 96 (110 x 300 x 2438)
16	Fork Spacing - Std Carriage - Maximum outside to outside edge	in (mm)	116.9 (2970)	116.9 (2970)	122.4 (3108)	122.4 (3140)
17	Mast tilt, forward / back	degrees	6/10	6/10	6/10	6/10
18	Overall length (length to face of forks)	in (mm)	229 (5876)	229 (5876)	241 (6121)	241 (6121)
19	Overall width	in (mm)	127 (6477)	127 (6477)	133 (3378)	133 (3378)
20	Height of Standard mast, lowered (Rounded Up)	in (mm)	139 (3517)	139 (3517)	143 (3616)	143 (3616)
21	Height of mast, extended w/o load backrest (Rounded Up)	in (mm)	199 (5042)	199 (5042)	203 (5141)	203 (5141)
22	Height to top of Std. overhead guard (high) (Rounded Up)	in (mm)	133 (3381)	133 (3381)	136 (3451)	136 (3451)
23	Height to top of Cab w/o airco (Rounded Up)	in (mm)	135 (3424)	135 (3424)	138 (3495)	138 (3495)
23	Height to top of Cab w airco (Rounded Up)	in (mm)	136 (3459)	136 (3459)	139 (3530)	139 (3530)
24	Towing coupling height	in (mm)	37.8 (960)	37.8 (960)	40.6 (1031)	40.6 (1031)
25	Outer turning radius	in (mm)	210 (5326)	210 (5326)	224 (5691)	224 (5691)
26	Inner turning radius	in (mm)	18.4 (469)	18.4 (469)	22.4 (569)	22.4 (569)
27	Load distance (load face-ctr of wheel to face of forks- front overhang) 2 stg	in (mm)	43.7 (1109)	43.7 (1109)	45.1 (1140)	45.1 (1140)
28	Right angle stack (add length of load)	in (mm)	253 (6426)	253 (6426)	269 (3833)	269 (3833)
29	90° intersecting aisle (w/load W=96in, L=96in HD & W=72in, L=72in HDS) w/pin carriage	in (mm)	179 (4548)	179 (4548)	189 (4787)	189 (4787)
30	Travel speed (RL/NL)	mph (km/hr)	16/17 (25/27)	16/17 (25/27)	16/17 (25/27)	16/17 (25/27)
31	Lifting speed (2-stage) (RL/NL)	ft/min (m/sec)	59/69 (.30/.35)	59/69 (.30/.35)	49/57 (.25/.29)	49/57 (.25/.29)
32	Lowering speed (2-stage) (RL/NL)	ft/min (m/sec)	98/98 (.50/.50)	98/98 (.50/.50)	98/98 (.50/.50)	98/98 (.50/.50)
33	Maximum drawbar pull with load	lbs (kN)	39,534 (176)	44,990 (200)	39,715 (177)	45,255 (201)
34	Drawbar pull @ 1.0 mph or 1.6 km/h with load	lbs (kN)	31,583 (140)	36,177 (161)	31,642 (141)	36,307 (162)
35	Gradeability max with load	%	30%	35%	25%	29%
36	Gradeability @ 1.0 mph or 1.6 km/h with load	%	24%	27%	20%	23%
37	Unladen weight (w/ std equipment: mast, carriage, forks, etc.)	lb (kg)	79,838 (36224)	79,838 (36224)	94,543 (42896)	94,543 (42896)
38	Axle loading laden w/ std option configuration (Front/Rear)	lb (kg)	123,838 (56188) / 11,099 (5036)	123,838 (56188) / 11,099 (5036)	146,630 (66529) / 14,033 (6367)	146,630 (66529) / 14,033 (6367)
39	Axle loading unladen w/ std option configuration (Front/Rear)	lb (kg)	38,453 (17447) / 41,385 (18777)	38,453 (17447) / 41,385 (18777)	46,231 (20976) / 48,312 (21920)	46,231 (20976) / 48,312 (21920)
40	Tire size-front		14.00 x 24 28PR	14.00 x 24 28PR	16.00 x 25 28PR	16.00 x 25 28PR
41	Tire size-rear		14.00 x 24 28PR	14.00 x 24 28PR	16.00 x 25 28PR	16.00 x 25 28PR
42	Wheelbase	in (mm)	144 (3655)	144 (3655)	155 (3935)	155 (3935)
43	Ground clearance under mast, laden	in (mm)	11.8 (299)	11.8 (299)	11.8 (299)	11.8 (299)
44	Ground clearance at center of wheelbase	in (mm)	16.7 (424)	16.7 (424)	19.8 (503)	19.8 (503)
45	Brakes Service - Method of Control/Operation		Hydraulic/Foot	Hydraulic/Foot	Hydraulic/Foot	Hydraulic/Foot
46	Brakes Park - Method of Control/Operation		Mechanical/Hand	Mechanical/Hand	Mechanical/Hand	Mechanical/Hand
47	Battery Type		Maintenance Free	Maintenance Free	Maintenance Free	Maintenance Free
48	Battery Volts/Cold Cranking Amps		2x 12V/900	2x 12V/900	2x 12V/900	2x 12V/900
49	Engine manufacturer/type		Cummins Diesel	Cummins Diesel	Cummins Diesel	Cummins Diesel
50	Engine output, in accordance with ISO 1585	hp (kw)	230 (172)	264 (197)	230 (172)	264 (197)
51	Torque	ft/lb (N-m)	675 (915)	830 (1125)	675 (915)	830 (1125)
52	Number of cylinders/displacement	No./cc (ci)	6/8300 (506)	6/8300 (506)	6/8300 (506)	6/8300 (506)
53	Gear change type		Elec. Controlled Powershift	Elec. Controlled Powershift	Elec. Controlled Powershift	Elec. Controlled Powershift
54	Transmission: Number of speeds forward/reverse		3/3	3/3	3/3	3/3
55	Fuel Tank - Capacity (Gasoline- or Diesel-Powered Units Only)	gal (liters)	81 (305)	81 (305)	96 (364)	96 (364)
56	Working pressure for attachments	psi (bar)	3260 (225)	3260 (225)	3260 (225)	3260 (225)
57	Oil flow for attachments	gal/min (l/min)	18.5 (70)	18.5 (70)	18.5 (70)	18.5 (70)
58	Towing coupling type		Pin	Pin	Pin	Pin
59	Hydraulic Tank - capacity (drain & refill)	gal (liters)	62.6 (237)	62.6 (237)	72.4 (274)	72.4 (274)

GENERAL

DIMENSIONS

PERFORMANCE

WT.

WHEELS & TIRES

TRANS. & POWER UNIT

H700HDS SPECIFICATIONS

GENERAL			Hyster Company	Hyster Company
1	Manufacturer		Hyster Company	Hyster Company
2	Model designation		H700HDS	H700HDS
3	Power Train - Engine Transmission		Cummins QSC 8.3 230hp	Cummins QSC 8.3 260hp
4	Transmission Type		Auto-Powershift	Auto-Powershift
5	Load capacity	lbs/kg	70,400 (32,000)	70,400 (32,000)
6	Load center	in (mm)	36 (900)	36 (900)
7	Drive Power Type: Gas, Diesel, LPG		Diesel	Diesel
8	Operation: Seated rider		Seated Rider	Seated Rider
9	Step Height (from ground to running board)	in (mm)	23.6 (600)	23.6 (600)
10	Step Height (btwn intermediate steps)	in (mm)	12.6 (320)	12.6 (320)
11	Tires: P=pneumatic, C=cushion, SC=supercushion		P	P
12	Number of wheels, front/rear (X = driven)		4X/2	4X/2
DIMENSIONS				
13	Fork carriage width - Standard Carriage	in (mm)	129 (3300)	129 (3300)
14	Fork Spacing - Std Carriage - Minimum Inside to inside edge	in (mm)	7.8 (198)	7.8 (198)
15	Fork dimensions	in (mm)	4.3 x 11.8 x 96 (110 x 300 x 2438)	4.3 x 11.8 x 96 (110 x 300 x 2438)
16	Fork Spacing - Std Carriage - Maximum outside to outside edge	in (mm)	122.4 (3108)	122.4 (3108)
17	Mast tilt, forward / back	degrees	6/10	6/10
18	Overall length (length to face of forks)	in (mm)	241 (6121)	241 (6121)
19	Overall width	in (mm)	133 (3378)	133 (3378)
20	Height of Standard mast, lowered (Rounded Up)	in (mm)	143 (3616)	143 (3616)
21	Height of mast, extended w/o load backrest (Rounded Up)	in (mm)	203 (5141)	203 (5141)
22	Height to top of Std. overhead guard (high) (Rounded Up)	in (mm)	136 (3451)	136 (3451)
23	Height to top of Cab w/o airco (Rounded Up)	in (mm)	138 (3495)	138 (3495)
23	Height to top of Cab w airco (Rounded Up)	in (mm)	139 (3530)	139 (3530)
24	Towing coupling height	in (mm)	40.6 (1031)	40.6 (1031)
25	Outer turning radius	in (mm)	244 (5691)	244 (5691)
26	Inner turning radius	in (mm)	22.4 (569)	22.4 (569)
27	Load distance (load face-ctr of wheel to face of forks- front overhang) 2 stg	in (mm)	45.1 (1140)	45.1 (1140)
28	Right angle stack (add length of load)	in (mm)	269 (3833)	269 (3833)
29	90° intersecting aisle (w/load W=96in, L=96in HD & W=72in, L=72in HDS) w/pin carriage	in (mm)	189 (4787)	189 (4787)
PERFORMANCE				
30	Travel speed (RL/NL)	mph (km/hr)	16/17 (25/27)	16/17 (25/27)
31	Lifting speed (2-stage) (RL/NL)	ft/min (m/sec)	49/57 (.25/.29)	49/57 (.25/.29)
32	Lowering speed (2-stage) (RL/NL)	ft/min (m/sec)	98/98 (.50/.50)	98/98 (.50/.50)
33	Maximum drawbar pull with load	lbs (kN)	39,604 (176)	45,145 (201)
34	Drawbar pull @ 1.0 mph or 1.6 km/h with load	lbs (kN)	31,531 (140)	36,196 (161)
35	Gradeability max with load	%	24%	28%
36	Gradeability @ 1.0 mph or 1.6 km/h with load	%	19%	22%
WT.				
37	Unladen weight (w/ std equipment: mast, carriage, forks, etc.)	lb (kg)	95,887 (43506)	95,887 (43506)
38	Axle loading laden w/ std option configuration (Front/Rear)	lb (kg)	153,427 (69613) / 12,988 (5893)	153,427 (69613) / 12,988 (5893)
39	Axle loading unladen w/ std option configuration (Front/Rear)	lb (kg)	46,337 (21024) / 49,550 (22482)	46,337 (21024) / 49,550 (22482)
WHEELS & TIRES				
40	Tire size-front		16.00 x 25 28PR	16.00 x 25 28PR
41	Tire size-rear		16.00 x 25 28PR	16.00 x 25 28PR
42	Wheelbase	in (mm)	155 (3935)	155 (3935)
43	Ground clearance under mast, laden	in (mm)	11.8 (299)	11.8 (299)
44	Ground clearance at center of wheelbase	in (mm)	19.8 (503)	19.8 (503)
45	Brakes Service - Method of Control/Operation		Hydraulic/Foot	Hydraulic/Foot
46	Brakes Park - Method of Control/Operation		Mechanical/Hand	Mechanical/Hand
47	Battery Type		Maintenance Free	Maintenance Free
48	Battery Volts/Cold Cranking Amps		2x 12V/900	2x 12V/900
TRANS. & POWER UNIT				
49	Engine manufacturer/type		Cummins Diesel	Cummins Diesel
50	Engine output, in accordance with ISO 1585	hp (kw)	230 (172)	264 (197)
51	Torque	ft/lb (N-m)	675 (915)	830 (1125)
52	Number of cylinders/displacement	No./cc (ci)	6/8300 (506)	6/8300 (506)
53	Gear change type		Elec. Controlled Powershift	Elec. Controlled Powershift
54	Transmission: Number of speeds forward/reverse		3/3	3/3
55	Fuel Tank - Capacity (Gasoline- or Diesel-Powered Units Only)	gal (liters)	96 (364)	96 (364)
56	Working pressure for attachments	psi (bar)	3260 (225)	3260 (225)
57	Oil flow for attachments	gal/min (l/min)	18.5 (70)	18.5 (70)
58	Towing coupling type		Pin	Pin
59	Hydraulic Tank - capacity (drain & refill)	gal (liters)	72.4 (274)	72.4 (274)

CERTIFICATION: These Hyster® lift trucks meet design specifications of Part II ANSI B56.1-1969, as required by OSHA Section 1910.178(a)(2) and also comply with Part III ANSI B56.1-revision in effect at time of manufacture. Certification of compliance with the applicable ANSI standards appears on the lift truck.

NOTE: Performance specifications / ratings are for truck equipped as described under Standard Equipment in this Technical Guide. Performance specifications are affected by the condition of the vehicle and how it is equipped, as well as by the nature and condition of the operating area. Specifications are subject to change and the proposed application should be discussed with your authorized Hyster Company Dealer.

STANDARD EQUIPMENT

- Cummins QSC 8.3 Turbo Diesel Engine
 - Tier 3 Compliant
 - 230 Peak Horsepower
- Spicer Off-Highway TE-17 3-Speed Auto shifting Transmission
- 2-Stage Vista Mast with maximum fork height of 124" (3160 mm)
- Carriage for 2-Stage Vista Mast
 - 122" (3100 mm) Wide Pin Type Carriage with Mechanical Fork Locks (w/o fork positioner) (H550HD/S)
 - 129"(3280mm) Wide Pin Type Carriage with Mechanical Fork Locks (w/o fork positioner) (H620-700HD/S)
- Wet Disc Brakes
- Planetary Drive Axle
- Closed-Center Hydraulic System featuring Variable Displacement Pumps
- 2 Function Hydraulic Control Valve with 2 Levers
- Mast Tilt: 6° Fwd / 10° Back
- Directional Control Lever
- Steer Wheel Nut Protection
- Open Operator Compartment with Integral Overhead Guard Featuring:
 - Seat-Side Hydraulic Control
 - Multifunction Display Panel
 - Interior Wide Angle Mirrors
 - Exterior Wide Angle Mirrors - Mounted to Handrails
 - Telescoping & Tilting Steering Column
 - Floor Mat
 - 24-12V DC Converter
 - Isolated Mounting for Low Noise and Vibration
 - Handrails for Operator Entry and Exist
- Steering Wheel with Spinner Knob
- Electronic Horn
- Mechanical, Full Suspension Vinyl Seat with integrated adjustable armrest and seat belt
- Operator Restraint System
- Operator Presence System
- Sy-Klone Spinner Type Heavy Duty Air Intake Pre-Cleaner
- Overhead Exhaust
- Lockable Battery Disconnect Switch
- 24V Electrical System
- 70 Amp Alternator
- Manual Tilt Operator Compartment for Service Access
- Light Kit 1
 - Front: 2 Halogen work lights on fender;
 - Rear: 2 Halogen work lights; 2 LED Stop / Tail / Back-up Lights
- Visible Alarm - Amber Strobe Light - Key switch Activated
- Audible Alarm - Reverse Direction Activated 82-102 dB(A) - Self adjusting
- Non-Locking Fuel Cap
- Literature Package
 - Operator's Manual
 - Service Manual
 - Parts Manual
- Warranty
 - 12 Months / 2,000 Hours Manufacturer's Warranty

OPTIONS

- Cummins QSC 8.3 Turbo Diesel Engine
 - Tier 3 Compliant
 - 264 Peak Horsepower
- 2-Stage Vista Masts with maximum fork heights from 124" (3155 mm) to 364" (9250 mm) for the H550HD/S and from 112" (2850 mm) to 388" (9865 mm) for the H620-700HD/S
- Carriage for 2-Stage Vista Mast H550HD/S
 - 122"(3100mm) Wide Pin Type Fork Positioner - Individual Fork Control
 - 122"(3100mm) Wide Pin Type Apron-Style Sideshift (w/o Fork Positioner)
 - 122"(3100mm) Wide Pin Type Apron-Style Sideshift Fork Positioner - Individual Fork Control
 - 118"(3000mm) Wide Hook Type Dual Function Sideshift Fork Positioner H620-700HD/S
 - 129"(3280mm) Wide Pin Type Fork Positioner - Individual Fork Control
 - 129"(3280mm) Wide Pin Type Apron-Style Sideshift (w/o Fork Positioner)
 - 129"(3280mm) Wide Pin Type Apron-Style Sideshift Fork Positioner - Individual Fork Control
 - 125"(3180mm) Wide Hook Type Dual Function Sideshift Fork Positioner
- COIL RAM (H620-700HD/S only) - Pin Carriage Mounted or Hook Carriage Mounted
- Hydraulic Valve Group
 - Hydraulic Control 3 way, 4 way, 5 way
 - Hydraulic Control 2-3-4-5 function Joystick
- Mast Tilt: 15° Fwd / 10° Back
- MONOTROL™ Pedal
- Front and Rear Mud Flaps
- Enclosed Cabin with or without Air Conditioning includes:
 - Seat-Side Hydraulic Control Levers
 - Multifunction Display Panel
 - Interior Wide Angle Mirrors
 - Telescoping & Tilting Steering Column
 - Floor Mat
 - 24-12V DC Converter
 - Front (single blade), Top & Rear Wipers
 - Heater
 - Re-circulation Fan
- Seats
 - Mechanical, Full Suspension Cloth Seat
 - Air Ride, Full Suspension Cloth Seat
 - Deluxe Air Ride Full Suspension Cloth Seat
- Powered Tilt Operator Compartment
- Various Light Kits
- Hydraulic Accumulator
- Lifting Eye Shackles
- Engine Block Heater-110V
- Mast Tilt Indicator
- Traction Speed Limiter
- Automatic Engine Shutdown

It's not just about the lift trucks.

Any company worth its weight knows success has just as much to do with the support before and after the sale as the sale itself. We pride ourselves on being more than just a lift truck manufacturer. Through our Dealer Network, we're also fleet managers, parts suppliers, capital procurement specialists and trainers. You'll find that when it comes to service, we do it all.

Hyster Fleet Services

As much as we'd like for your entire fleet to be Hyster, we know that's not always the case. But just because you also operate other brands doesn't mean we can't manage your lift truck maintenance and replacement plan. We can analyze your current fleet or provide summary of your fleet history and a cost-effective proposal for replacement and scheduled maintenance of all your vehicles. Once this initial review is complete, we'll continue to monitor your fleet to ensure it's performing optimally.

UNISOURCE™ Parts Program

In addition to providing fleet management for a variety of brands, we can also serve as your source of parts for all your lift trucks. With the Hyster UNISOURCE parts and service program, we offer approximately 2 million part number crosses for most brands of materials handling and other in-plant mobile equipment. UNISOURCE also has remanufactured parts that provide the same quality and guarantee but at a lower price. And we can deliver parts to you in less than 24 hours, any day of the week. How's that for convenience?

Rental Products

At Hyster Company, we're always looking for ways to help you keep your productivity up. Through the Hyster Dealer Network, you can access rental equipment for the times when leasing or buying isn't a practical option. Your local Hyster Dealer has access to over 14,000 units that are available for short- or long-term rental. Whether you need one truck to substitute for a vehicle that's being serviced or several lift trucks to accommodate seasonal changes in your business, we'll help you maintain output in a cost-effective manner.

Hyster Capital

We know that financing new additions to your fleet can sometimes be challenging. That's why your Hyster Dealer has a long list of ways for you to fund your purchase. We are skilled in arranging solutions for special financing requirements, taking the difficulties out of buying the equipment you need. Whether you purchase or lease a new or used lift truck, Hyster Capital offers better service and competitive rates, ensuring you receive the value you deserve.

Special Products

Engineering Department (SPED)

In a perfect world, every application could be handled with a standard lift truck. However, in the real world, different materials require different handling. That's why Hyster Company's Special Products Engineering Department works with you to customize* your lift trucks. From strobe lights to specially made forks, SPED can provide you with the tools you require to get the job done right.

** May be subject to an additional charge. Contact your local authorized Hyster Dealer for more information.*

Automated Warehouse Solutions

As society's technological capabilities advance, we strive to find practical applications. One of our most recent innovations in that pursuit is our development of automated warehouse solutions. We can help you determine if your operation would benefit from this type of system, which improves inventory accuracy, warehouse productivity and safety records, as it reduces maintenance and overtime.

Operator and Service Training

Hyster Company recognizes that proper training is a key element of a profitable company. That's why your local authorized Hyster Dealer offers a training program for your lift truck operators as well as those who maintain your vehicles. Proper education in running and servicing lift trucks cuts down on the number of repairs and risk of injuries due to accidents while increasing productivity. All of our trainers are professionals with experience in materials handling.



Hyster Company
P.O. Box 7006
Greenville, North Carolina
27835-7006
Part No. H550-700HD/S/BTG
3/2010 Litho in U.S.A.

Visit us online at www.hysteramericas.com
or call us at 1-800-HYSTER-1.

Hyster, , Fortis, and MONOTROL are registered trademarks of Hyster Company. Hyster products are subject to change without notice.

Cummins, Sy-Klone, Spicer, Delco, and Donaldson are registered trademarks of their respective companies.

The Hyster Company products included in this document may be covered by U.S. Patent 6,684,148 and other patents pending. Truck on cover shown with optional equipment. ©2010 Hyster Company. All rights reserved.

